ERICH BECKER

**MECHANICALLY
DRIVEN DIAPHRAGM
PUMPS FOR USE
WITH GASES**

VULKAN-VERLAG PUBLISHERS, ESSEN

VULKAN PUBLISHERS, ESSEN

Becker, Erich:

Mechanically Driven Diaphragm Pumps for Use with Gases:
[Fundamentals - design - applications] / Erich Becker - Essen:
Vulkan Publishers, 1997

ISBN 3-8027-2187-X

All rights reserved, in particular the right of translation into other languages. Any reproduction of this pocket book or parts thereof, the use of illustrations therein, its transmission by wireless, reproduction by photomechanical means (photocopies, microcopies) or its storage in data processing systems is subject to the explicit approval of the publishers.

© Vulkan-Verlag, Essen, Germany - 1999

Original booklet printed in Germany

The use of trade names, product names or similar in this work, even when not specifically identified as such, does not imply that they have for legal purposes acquired a non-proprietary or general significance.

Formatted in Acrobat® PDF for presentation on the web by
Richard Rauth, Manager of Marketing Communications
KNF Neuberger, Inc.
Trenton, NJ USA

Reprinted with permission
from the publisher, Vulkan-Verlag Essen

Foreword

Whether in medical technology, environmental protection/analysis, in the laboratory or process engineering, many applications are today unthinkable without the use of mechanically driven diaphragm pumps for gases. Their particular properties such as oil-free, maintenance-free and uncontaminated operation make them suitable for numerous fields of application. Despite their wide distribution, they are treated only marginally, if at all, in the general literature and, up until now, there has been neither a general account nor a comprehensive summary account of these pumps.

The intention of this book is to fill this gap and provide an overview of the diaphragm pumps with mechanical drive. In addition, examples of applications and advice concerning selection of the right pump are included in the subject matter.

This book will serve to inform and stimulate both the engineer constructively working on design plans, and the engineer undergoing training.

Table of Contents

Foreword	3
1 Introduction	6
1.1 <i>A brief glimpse of the past</i>	6
1.2 <i>A systematic classification of diaphragm pumps with mechanical diaphragm drive for gases</i>	7
2 Design function and properties of diaphragm pumps for gases ..	9
2.1 <i>Design and function of different types of diaphragm pumps</i>	10
2.1.1 <i>Diaphragm pumps with eccentric drive</i>	10
2.1.2 <i>Diaphragm pumps with magnetic vibrator systems</i>	12
2.2 <i>Characteristics of diaphragm pumps</i>	14
2.3 <i>Fundamentals concerning diaphragms and valves</i>	16
2.3.1 <i>Diaphragms</i>	16
2.3.2 <i>Valves</i>	21
2.4 <i>Regulation of the flow rate</i>	22
2.5 <i>Connections of double-headed pumps</i>	22
2.6 <i>The development of noise</i>	23
2.7 <i>Service life of the diaphragm pumps</i>	25
3 Types of diaphragms	27
3.1 <i>Basic design</i>	27
3.1.1 <i>Flat diaphragm</i>	27
3.1.2 <i>Molded diaphragm</i>	30
3.1.3 <i>Structured diaphragm</i>	33
3.1.4 <i>Summary comparison of flat diaphragm, molded diaphragm and structured diaphragm</i>	35
3.2 <i>Other types of diaphragms</i>	35
3.2.1 <i>Convolute diaphragm</i>	35
3.2.2 <i>Wave diaphragm</i>	36
3.2.3 <i>Diaphragm with PTFE coating</i>	36

4	Special varieties of diaphragm pumps	37
4.1	<i>Diaphragm pumps with low leak rates</i>	37
4.2	<i>Double diaphragm pumps</i>	38
4.3	<i>Corrosion-resistant diaphragm pumps</i>	39
4.4	<i>Temperature-resistant diaphragm pumps</i>	42
4.5	<i>Heated diaphragm pumps</i>	44
5	Appendix: High-speed liquid diaphragm pumps	46
6	Applications	50
7	Advice concerning the selection of a pump	53
8	References	57
9	Bibliography	58

1 Introduction

1.1 A brief glimpse of the past

It is not known who developed the first diaphragm pumps nor when. Already in the 16th century before Christ, bellows are depicted in the Egyptian temple paintings at Karnak that were used as bellows for fire in the hearth, for processing metal [1]. These bellows can be considered as the precursor of present-day diaphragm pumps. The bellow made of leather took on the task of a diaphragm.

In the 1940s, the USA started an extensive program to help synthetic elastomers achieve a worldwide breakthrough, in response to the depletion in supply of natural rubber from Southeast Asia during the Second World War [2,3]. In so doing, the Americans were able to fall back on the fundamental work of the German Buna works. Using high-quality elastomer materials, new technical possibilities eventually opened up for the design and use of diaphragm pumps (for example, for the transfer of dirty water, and also for medical purposes). Later, hydraulically driven diaphragm compressors came onto the market that were able to produce high pressures of up to 4,000 bar. These pumps employed the principle of a metal diaphragm supported by hydraulic oil and set into oscillating movement.

In the early 1960s, diaphragm pumps with a mechanical drive for gases gained in importance. The availability of high-quality, temperature-resistant elastomers with excellent mechanical and aging properties set a tumultuous wave of development in motion. As a result of new design construction, success was reached in increasing the low performance range of diaphragm pumps. Development was not confined, however, to producing ever larger pumps. Constantly smaller constructions with pump capacities of 0.2 l/min were, and are, the response to the tendency for miniaturizing equipment in many important fields of application for the pumps.

Over the past 35 years, diaphragm pumps with mechanical diaphragm drives have, as a result of their versatile properties, secured a firm place in measurement techniques and control engineering, in medical technology, in the laboratory, and in numerous other areas of application. In addition, further developments and application-related adaptations have likewise made a contribution. With the establishment of a corrosion-resistant design in 1964 and the universal chemical-resistant designs since 1980, new applications in chemistry, process engineering, and especially in the laboratory became possible. Further use of these pump types in space and in nuclear engineering underscore the leading technical position of the diaphragm pump with mechanical drive.

1.2 A systematic classification of diaphragm pumps with mechanical diaphragm drive for gases

The pumping of media is a standard task in technology. To begin with, the pumps used can be categorized according to the type of medium to be transferred: gas and liquid. Although diaphragm pumps are also available for liquid media, the following account is limited to gas pumps - with the exception of Chapter 5. This restriction is based on the fact that diaphragm pumps with a mechanical diaphragm drive for liquids can be distinguished from the corresponding gas pumps in terms of both the physical fundamentals as well as design. While in the literature liquid diaphragm pumps are treated at length, a corresponding consideration of diaphragm gas pumps is lacking.

Classified according to pumping principle, diaphragm pumps for gases belong to gas transfer pumps, as well as displacement pumps and, in turn, to reciprocating displacement pumps. Incidentally, reciprocating piston pumps also belong to this family.

A further classification of gas pumps is made according to function:

- transfer pumps
- compressors
- vacuum pumps

Most diaphragm pumps found in the market may be used as either transfer pumps, compressors, or vacuum pumps. Other diaphragm pumps are specially designed as compressors or vacuum pumps. The term "diaphragm pump" mentioned throughout this book refers to a pump which can transfer, compress, and evacuate.

A special form of diaphragm pump for gases is the diaphragm compressor for achieving higher pressures. Diaphragm compressors are equipped with a hydraulically operated metal diaphragm. Maximum pressures of up to 4000 bar can be attained [4]. With their diaphragm-drive system (hydraulic instead of mechanical), their range (high pressure), and intended purpose (only compression, no transfer or evacuation), diaphragm compressors do not fall under the subject area of this book.

Maintaining the specific advantages of the diaphragm pump such as being oil free and maintenance free, diaphragm pumps with mechanically driven diaphragms cover the following performance spectrum:

- flow rate of up to 300 l/min
- pressures of up to 7 bar g (i.e., 8 bar absolute) single stage, and 16 bar g two stage
- ultimate vacuum of down to < 0.5 mbar (absolute)

In view of the potential of high-pressure compressors, high vacuum or ultra high vacuum pumps, this performance range may lead to the assumption that diaphragm pumps with mechanical diaphragm drive are a relatively unimportant type of pump. This conclusion is completely wrong because within the range of diaphragm pumps with a mechanical diaphragm drive, there is a large wealth of ambitious applications. Additionally, the diaphragm pump contrasts with other types of pumps, in many applications, in terms of a few important properties:

- simple and inexpensive construction
- oil-free operation
- no maintenance is necessary
- genuine transfer of the media
- high gas-tightness

This combination of properties makes diaphragm pumps a product which, in many applications, is without competition and which could turn out to be actually one of the most important types of pumps. For details regarding the properties, refer to Section 2.2.

2 Design function and properties of diaphragm pumps for gases

The basic construction of a diaphragm pump is simple (see Figure 1). An elastic diaphragm (1), clamped, pressure-tight, between the pump head (2) and the housing (3), separates the transfer compartment (7) from the interior of the housing. The diaphragm is connected, pressure tight, to the connecting rod (4) with the diaphragm-fixing screw (6). A drive in the interior of the housing sets the connecting rod in oscillation and causes the diaphragm to move up and down. In the downward thrust, the diaphragm sucks in the medium via the suction valve (8). In the upward thrust, it forces out the medium via the pressure valve (9).

Three different techniques are used for driving the diaphragm pumps for gases, (see Figure 2): drive via an eccentric drive; drive using a magnetic vibrator system; and, as a special constructional design for higher pressures, hydraulic drive. The type of drive to a large extent determines the capacity of the diaphragm pump flow rate – working pressure and maximum vacuum.

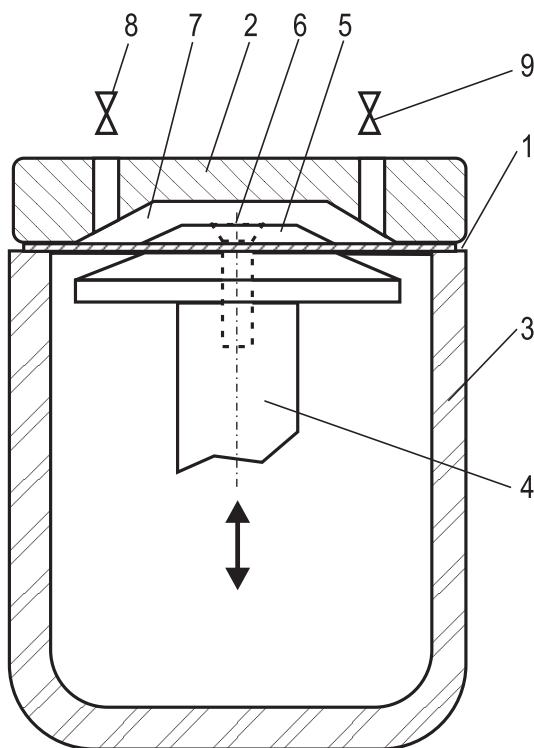

Figure 1: Basic construction of a diaphragm pump

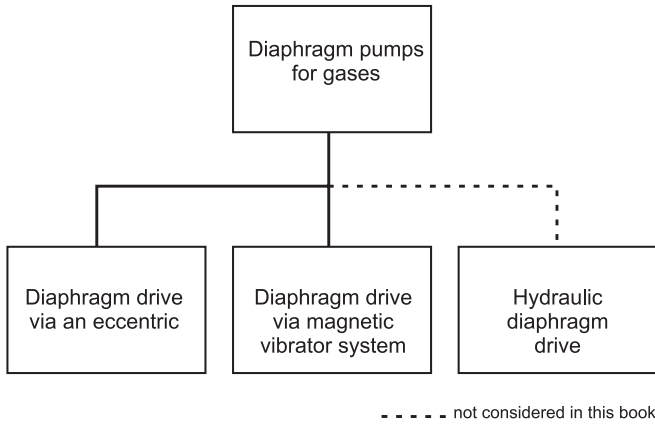

Figure 2: Classification of diaphragm pumps for gases according to type of drive

2.1 Design and function of different types of diaphragm pumps

2.1.1 Diaphragm pumps with eccentric drive

Eccentric drive is the most widespread type of drive for diaphragm pumps. In function (see Figure 3): the eccentric (2), driven via a shaft by an electric motor, displaces a connecting rod (3) in an upward and downward movement, and the connecting rod transfers the movement to the diaphragm (1). By means of the eccentric, the connecting rod is additionally set into swinging and tilting motion. This is taken into account in the geometrical design of the compression chamber so that the diaphragm is not squeezed between the connecting rod head and the contour of the compression chamber during upward motion.

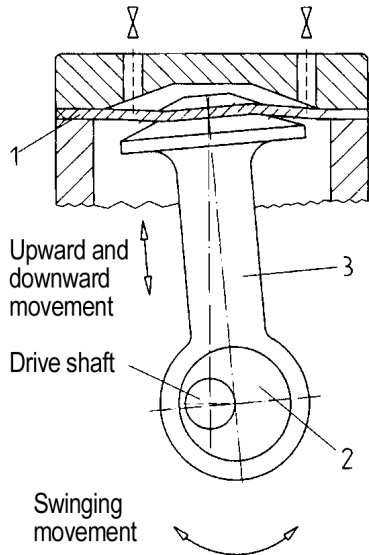

Figure 3: Basic design of the diaphragm pump with eccentric drive

Generally, a two- or four-pole alternating current motor is used for the drive. The eccentric drive enables the conversion of the moment of rotation of the motor into relatively high forces on the upward and downward motion of the connecting rod.

As such, diaphragm pumps with eccentric drive are well suited for producing high pressures within the limits of the load-carrying capacity of the diaphragm material. Another significant advantage of an eccentric drive is that pumps so equipped can be operated in every mounting orientation.

Diaphragm pumps with eccentric drive cover the following range:

- flow rate of 0.2 l/min to 300 l/min (measured with air and referred to the normal condition: temperature $t = 0\text{ }^{\circ}\text{C}$, pressure $p = 1.013\text{ mbar}$)
- pressures of up to 7 bar g (i.e., 8 bar absolute) in single-stage design, and up to 16 bar g in two-stage design
- vacuums of down to 100 mbar absolute in one-stage design, down to $< 0.5\text{ mbar}$ absolute in multi-stage design

Figures 4 and 5 illustrate a diaphragm pump with eccentric drive – as a cut-away drawing and as the finished product. For the designs illustrated, an asynchronous motor is integrated in the pump housing. This type of design is ideal for small and medium-sized construction sizes, and especially for portable designs.

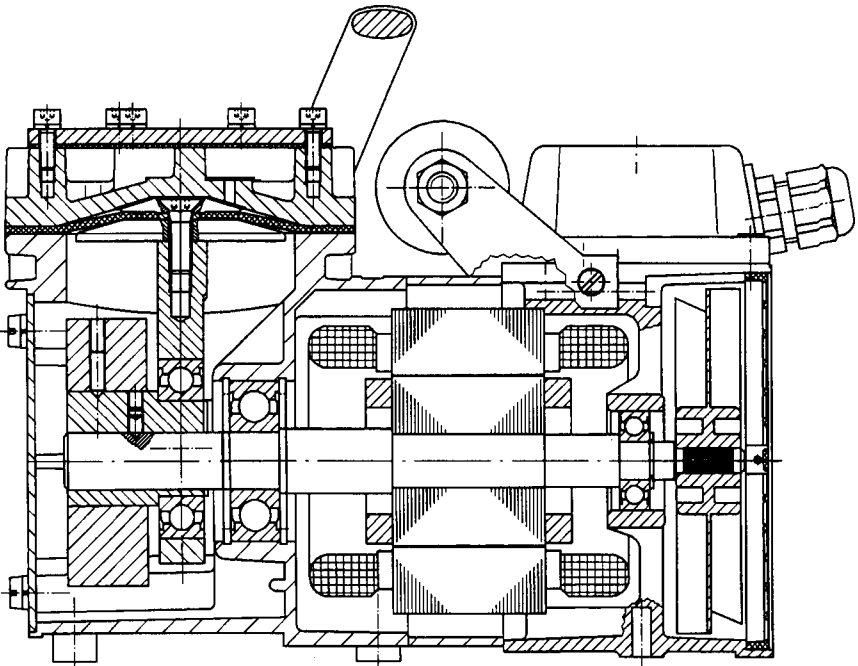

Figure 4: Cut-away drawing of a diaphragm pump with an eccentric drive

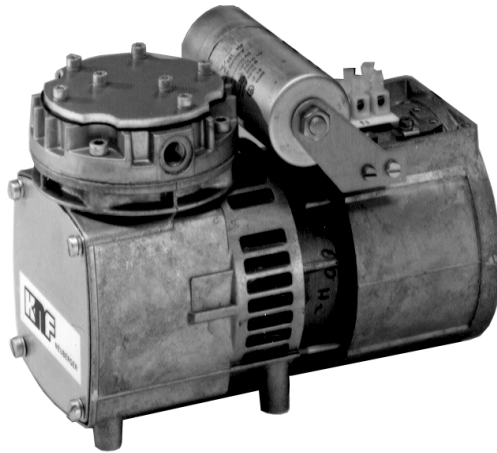

Figure 5: Diaphragm pump with an eccentric drive

In addition to the asynchronous alternating current motor, asynchronous three-phase A.C. motors are used as a drive. For small pumps, direct current motors, and in special cases, compressed air motors are also used.

2.1.2 Diaphragm pumps with magnetic vibrator systems

Diaphragm pumps with magnetic vibrator systems - the so-called linear pumps (see Figure 6) - are characterized by an especially technically elegant drive.

They are, in general, operated with a sinusoidal alternating current from the mains supply. In special cases, for example in the case of battery operation, direct current is transformed electronically into sinus or sinus-like impulses. The alternating current is fed to the electromagnet (1) via a diode. The magnet, excited electromagnetically, attracts the armature (2) during the first voltage half-wave. The diode suppresses the second voltage half-wave, so that the magnetic force declines. Thanks to the elastic spring force of the leaf spring (3), the armature returns to its starting position. In this way, the frequency of the electric voltage sets the diaphragm (4) via the connecting rod bolt (5) into oscillatory motion, which brings about the pumping process.

In order to achieve the optimal flow rate, the spring mass system of such a pump must work resonantly. For that purpose, the frequency of the supply voltage must be equal to or lie close to the spring mass system's natural frequency.

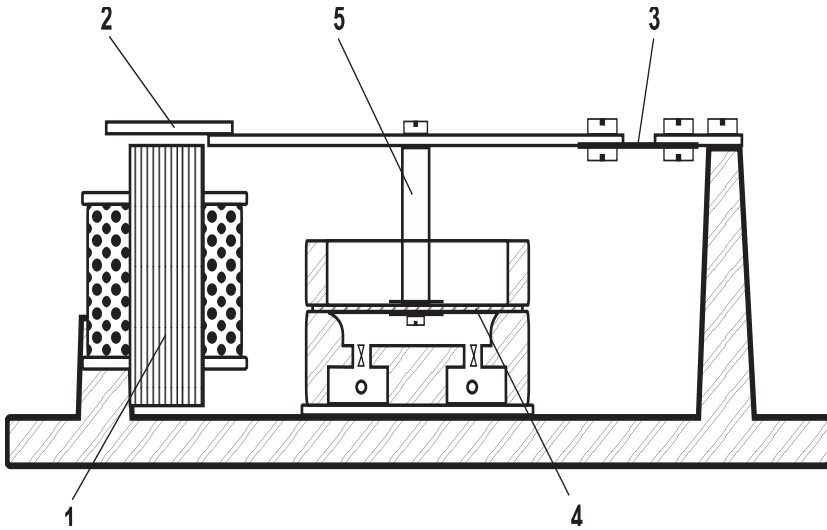

Figure 6: Basic design of the diaphragm pump with magnetic resonance system (linear pump)

If a linear pump designed for 50 Hz is, for example, operated at 60 Hz, it works outside resonance and the performance of the pump clearly declines.

The gas forces, acting on the armature arm as a result of the pumping process via the diaphragm (4) and the connecting rod bolt (5), attenuate the resonance system. Increasing pressure or negative pressure therefore reduce the amplitude of resonance and result in a reduced flow rate. The flow rate as a function of the pressure relationships is shown in Figure 7, in a comparison of diaphragm pumps with magnetic resonance systems and those with an eccentric drive. Two pumps with the same rates of flow serve as a basis for the comparison.

Diaphragm pumps with magnetic resonance systems cover the following output range:

- flow rate up to approximately 20 l/min (per unit)
- pressures up to approximately 1.2 bar g
- vacuums down to approximately 300 mbar absolute

Because of their output characteristics, these pumps are generally used for transferring, only rarely for applications involving evacuation, and practically not at all as compressors.

Because of their low pneumatic outputs and the resonance drive, diaphragm pumps with a magnetic resonance system operate under low driving powers and are very quiet. When using them, attention should be paid that they are not mounted on a vibrating base.

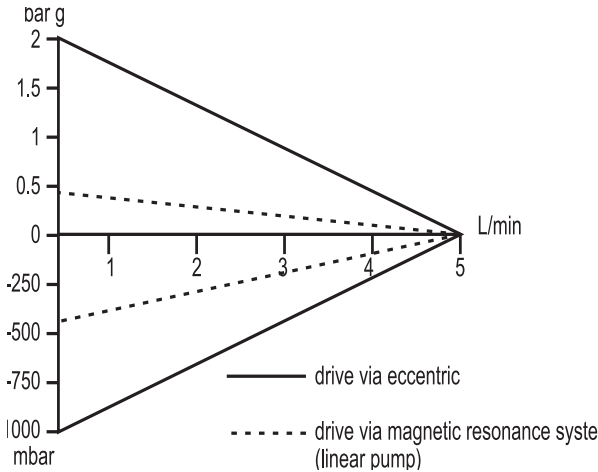

Figure 7: Comparison of flow rates of diaphragm pumps as a function of pressure relationships (selected example; idealized representation)

Likewise, linear pumps may not be connected to vibrating pneumatic systems. In both cases, the pump's vibrating system can be affected by interference. In contrast to diaphragm pumps with eccentric drive, linear pumps cannot be installed in every mounting orientation. In order to guarantee the function of the pump and a long service life, they may only be operated horizontally. Only under special conditions may they be operated in a vertical position.

Because of their limited range and limiting operating requirements, diaphragm pumps with a magnetic resonance system prove to be 'niche products' compared with eccentric-driven diaphragm pumps. This book therefore concentrates on diaphragm pumps with eccentric drive for the transfer, evacuation, and compression of gases.

2.2 Characteristics of diaphragm pumps

Because of their design principle, diaphragm pumps possess a range of special properties. One of the most important is their being free of oil. In contrast to a piston compressor whose cylinder course must generally be lubricated, a diaphragm pump, thanks to its elastic diaphragm, requires no lubricating. Consequently, no grease can come into contact with the gases to be transferred or compressed. They are, therefore, neither contaminated by foreign matter nor

by their combustion residue. The oil-free operation of the diaphragm pump has demonstrated itself to be an important property, particularly in medical and analytical instrumentation.

An additional excellent property of diaphragm pumps is their high gas-tightness. Other compressors, working according to the piston principle, require seals for sealing the piston in relation to the compression chamber (e.g., piston rings or lip seals). This also applies in principle to rotating systems, such as multi-cell compressors, roots pumps, or vane pumps. As a result of these seals, a part, however small, of the transferred, compressed, or evacuated gases escapes. Due to the seals wearing and because of arising friction, the sealing properties are reduced so that with an increasing period of operation, the loss of gas increases. With diaphragm pumps, in contrast, the diaphragm is firmly fixed on the connecting rod as well as between the pump housing and pump head, and in both positions practically no gas can escape. The fixed regions are static and consequently not exposed to wear. In the fixed regions, the diaphragm takes on the function of a flat seal. The double function of the diaphragm as a sealing organ and as a compressing organ allows for the simple and economic construction of the diaphragm pump. Because of their gas-tightness, diaphragm pumps are very well suited for dangerous or poisonous gases, and likewise for sample gases. For these, the quantitative as well as the qualitative adulteration of the medium must be ruled out.

Thanks to the principle-related gas-tightness, diaphragm pumps can achieve a leak rate of $\leq 10^{-3}$ mbar l/sec with little additional constructional expenditure. With a corresponding design of the fixing region (less unevenness of the seal surfaces, and optimal surface compression) and the sealing of the valve region with O rings, leak rates of up to 5×10^{-9} mbar l/sec can be achieved (see Section 4.1).

With the sealing of vapors and also with use as a vacuum pump, condensate may arise in the compression chamber. In pumps lubricated with oil, this results in contamination of the lubricating oil and often, as a consequence, the damaging of the pump because of increased friction. Working without oil lubrication, the diaphragm pump does not have such difficulties. If, in extreme cases, so much condensate accumulates that, because of the internal resistance of the pump the drive motor is overloaded, it is sufficient to empty the compression chamber. The pump will then continue to operate without fault.

For applications in which the condensate produces corrosive properties, the gas-transferring components of the diaphragm pump are made of corrosion-resistant materials. For these applications, high-grade steel as well as appropriate plastics that are mechanically durable, non-abrasive, and temperature resistant can be used. Plastics are generally preferred in the case of pumps with

less pneumatic performance, whereas with a larger constructional volume, high-grade steel or ceramics are used. Section 2.3.1 refers to the corrosion resistance of diaphragms.

Because lubrication of the pumping components is eliminated with diaphragm pumps with eccentric drive, the drive mechanism of the pump (shaft and eccentric bearing) is designed without oil lubrication. For very low outputs, self-lubricating, sliding bearings can be used. In general, however, grease-lubricated ball bearings are used. With the corresponding constructional design of the drive, sliding bearings as well as ball bearings can be operated in every orientation. In combination with the robust drive mechanism, via the eccentric, as well as eliminating operating liquids, diaphragm pumps with eccentric drive can be operated in every mounting orientation. The diaphragm pump with eccentric drive is the only diaphragm pump that enables use independent of orientation.

The only wearing parts of a diaphragm pump are the diaphragms and, to a small extent, the valves. In the case of pumps with an eccentric-operated diaphragm, the ball bearings can be added to this list, and to linear pumps the armature spring. When correctly operated, diaphragm pumps can be considered maintenance-free. With the corresponding design of the pump (e.g., with durable ball bearings) only the diaphragms and perhaps the valves will require replacement after long intervals.

2.3 Fundamentals concerning diaphragms and valves

2.3.1 Diaphragms

The heart of the diaphragm pump is the diaphragm. It not only gives the pump its name, but also provides it with the specific properties such as with the elimination of oil and gas-tightness.

The main function of the diaphragm is to displace the working gases from the compression chamber. At the same time, it has to take over control of part of the connecting rod on the membrane side, in order to effect a linear movement. The importance of this control function should not be underestimated. For example, the greater the maximum vacuum required from a diaphragm pump, the greater the required compression ratio of the pump. This requires, at the upper dead point of the diaphragm, smaller distances between the diaphragm with the diaphragm fixing disk and the wall of the compression chamber. An exact linear guidance of the connecting rod ensures that neither the diaphragm nor its fixing plate strike the wall.

In addition to the pressure force P_D (resulting from the gas pressure), the diaphragm must also take up the tractive power P_F ; this results from the stretching

of the diaphragm (see Figure 8). Elastomers, as well as the diaphragm, deform under the transmission of forces, as the result of their elastic properties. If, in the neutral position of the diaphragm, the length between the diaphragm retainer on the pump head and on the connecting rod/retainer plate l_0 is at the lower dead point of the diaphragm roughly

$$l_{UT} = \sqrt{(l_0^2 + h_u^2)},$$

with the traverse h_u between the neutral position and the lower dead point. The deformation of the diaphragm resulting from this prevents the necessary precise linear guidance of the upper connecting rod component. In the vicinity of the upper dead point, there is consequently the danger that the diaphragm-retaining plate may strike the housing or the inner wall of the compression chamber. If so, fracture of the connecting rod and mechanical damage to the diaphragm can be the consequence. In order to avoid such problems, diaphragms are equipped with a tissue insert to improve the absorption of the forces. The tissue is vulcanized in, in the neutral region of the diaphragm.

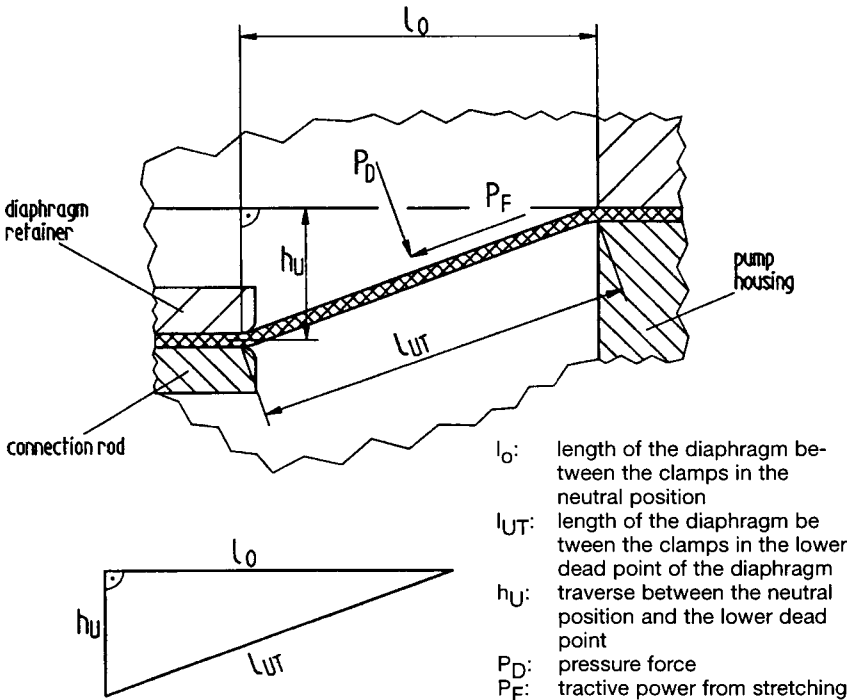

Figure 8: Length and force relationships on the diaphragm

Tissue with synthetic fibers have almost taken the place of natural fibers such as cotton or silk, in the technical field. Figure 9 illustrates the most commonly

used tissue materials and their physical properties. Deep-drawing quality and tensile strength refer to the processing of the tissue material.

Description	Tensile strength	Deep-drawing quality	Bonding strength
Polyester tissue	good	good	average
Polyamide tissue	high	limited	good
Aramide tissue	average	average	good

Figure 9: Tissue materials for strengthening diaphragms together with their physical properties.

Source: among others, according to Carl Freudenberg Dichtungs- und Schwingungstechnik KG: 'Simirit® Standardkatalog'

In the diaphragm, longitudinal stretching causes tensions. These can be calculated approximately using Hook's law for springs:

$$\sigma = E \times \varepsilon$$

(tension = elasticity modulus x extension)

$$\varepsilon = \frac{\Delta l}{l_0} = \frac{l_{UT} - l_0}{l_0}$$

(Extension = lengthening / initial length)

An exact calculation of the total strain on a diaphragm is very complicated. The most diverse factors having an effect are diaphragm strength, diaphragm hardness, operating temperature and type of tissue. All should be taken into account. What is also relevant is that the elasticity modulus of rubber-elastic materials is not constant, but can, for example, increase as well as decrease with stretching. In practice, diaphragm materials have stood the test with Shore A hardness values of between 50 and 60. When such materials are additionally equipped with a polyamide tissue, the longitudinal extension of $\varepsilon = 4\%$ should not be exceeded. Lower extension values have a positive effect on the service life of the diaphragm.

With diaphragm pumps with high outputs or low maximum pressures in the dead point of the diaphragm, the outer diaphragm region lies on the inner wall of the compression chamber because of the necessary small dead volume. In order that this 'touching' does not result in heavy wearing of the diaphragm, materials very resistant to abrasion must be used. Chlorobutadiene caoutchouc (CR, neoprene) and acrylonitrile butadiene caoutchouc (NBR, perbutane) offer themselves as the basic elastomers. In order to minimize the coefficient of friction between the diaphragm and the wall of the compression chamber, the wall must possess a high surface quality.

In addition to extension and friction, thermal effects result in diminished diaphragm quality. If high operating temperatures act on an elastomer, particularly

long-term, aging brought about by oxidation and partly by vulcanization results. This has the consequence of an increase in hardness and a decrease in elasticity and flexibility. With continued aging, cracks appear on the surface of the diaphragm that eventually result in mechanical destruction. At low temperatures, as well, the elastomer diaphragms become harder and stiffer, and regression of the deformations proceeds more slowly.

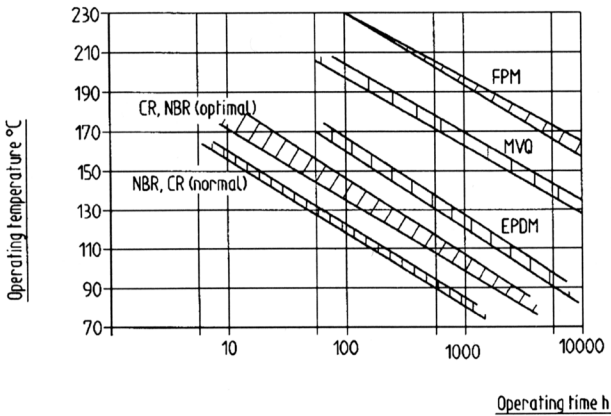

Figure 10: Permissible temperature/time limits for different elastomers under the influence of warm air (for the designation of elastomers, see Figure 11). According to Freudenberg Dichtungs- und Schwingungstechnik, "Diaphragm als Konstruktionselement", Page 7.

Within the context referred to, the operating temperature of the media to be pumped plays a significant role in deciding on a particular diaphragm material since the diaphragms certainly show acceptable application times within temperature limits. While optimally prepared diaphragms from CR or NBR materials can be used at an operating temperature of 170 °C for just 10 hours (see Figure 10), at 80 °C use may be a few thousand hours (considering solely the thermal load). Fluorocautchouc diaphragms (FPM) in contrast also attain acceptable application times at higher operating temperatures. In most applications for diaphragm pumps, the temperature of the medium to be pumped lies between 5 °C and 40 °C: in this case, longer hours of life for the diaphragm can also be achieved with the selection of the inexpensive materials such as chlorobutadiene-caoutchouc (CR) and acrylonitrile-butadiene-caoutchouc (NBR).

As already noted, diaphragm pumps can also be used for the transfer, compression and evacuation of corrosive media. In these cases, the diaphragms must be corrosion-resistant against the corresponding media. With the selection of diaphragm materials, one can refer to resistance tables (see Figure 11) for advice. Standard materials such as CR and NBR are valuable only against a few corro-

sive media while ethylene-propylene-diene-caoutchouc (EPDM) and fluoro-caoutchouc (FPM) have a distinctly higher resistance. Universally resistant is per-fluoro-caoutchouc (FFPM, trade names Simriz® and Kalrez®); the active substance is, however, so expensive that it cannot be considered as a diaphragm material. If it could be guaranteed as being universally resistant, diaphragms made of NBR, CR or EPDM would be coated with polytetrafluoroethylene (PTFE, trade name Teflon®) See Section 3.2.3 for additional information on this topic.

Table of resistance for diaphragm materials

NBR	Acrylobutadiene-caoutchouc (Perbunane)	EPDM	Ethylene-propylene-diene-caoutchouc (Vistalon)
CR	Chlorobutadiene-caoutchouc (Neoprene)	PTFE	Polytetrafluoroethylene (Teflon)
MVQ	Vinyl-methyl-polysiloxane (Silicone)	FFPM	Per-fluoro-caoutchouc (Simriz, Kalrez)
FPM	Fluoro-caoutchouc (Viton)		() = trade name

Resistance against:	NBR	CR	MVQ	FPM	FFPM	EPDM	PTFE
Acetone	C	C	C	C	A	A	A
Ammonia	B	E	E	C	A	A	A
Benzene	A	B	C	A	A	C	A
Benzol	C	C	C	B	A	C	A
Butadiene	A	B	B	A	A	C	A
Chlorine	C	C	D	A	A	A	A
Natural gas	A	A	A	A	A	B	A
Fluorine, dry	C	E	E	E	A	E	A
Hydrofluoric acid, conc.	E	E	E	E	A	B	A
Carbon monoxide	A	A	A	A	A	A	A
Methanol	B	B	A	A/C	A	A	A
Caustic soda	B	B	C	C	A	A	A
Ozone	E	B	A	A	A	A	A
Propane	A	A	A	A	A	E	A
Nitric acid	B	B	B	A	A	B	A
Hydrochloric acid	A	B	E	A	A	A	A
Salt water	A	A	E	A	A	A	A
Sulphur dioxide	C	C	D	A	A	A	A
Toluene	C	C	C	B	A	C	A
Hydrogen	A	A	A	A	A	A	A
Xylene	C	C	C	B	A	C	A

A = Little or no corrosion	D = No data available, probably suitable
B = Weak to moderate	E = No data available, probably not suitable
C = Strong corrosion to complete destruction	

Figure 11: Table of resistances for diaphragm materials.

Source: Carl Freudenberg Dichtungs- und Schwingungstechnik KG
'Simirit® Standardkatalog'

The table of resistances is based on the results of laboratory investigations. As relatively high temperatures arise when the diaphragms are in operation and the dynamic loads described above are added to this, the values given in the tables serve only as approximate values.

2.3.2 Valves

As is the case with most reciprocating piston machines, the inflow and outflow of the feed current is effected by self-acting valves. They open and close as a function of the difference in pressure that results from the altered volume of the working space in the suction line or the pressure line. In general, they are designed as flapper valves (Fig. 12). For pumps working at low pressure, in each case, a circular, non-fixed elastomer disk is used as the valve element on the suction side as well as on the pressure side.

Optimal synchronization of the opening and closing speed of the valves has a large effect on the volumetric efficiency of the diaphragm pump. Therefore, the valve lift must be so chosen that with the speed of $n = 1,480$ 1/min or 2,800 1/min, typical for diaphragm pumps, the valves open and close fast enough. The mass of the valve tongue and its resetting force will likewise have an effect on the speed of opening and closing.

Either spring metal or elastomers such as neoprene, perbunane or EPDM are used as materials for the valve tongues. For corrosion-resistant designs, PTFE finishes are used. As the material for valve plates, per-fluoro-caoutchouc (FFPM, trade name Kalrez®) has, in the meantime, come into use.

The heat of compression and frictional heat, which often arise as a result of the high speed of the transfer medium, result in relatively high temperatures on the valve tongues.

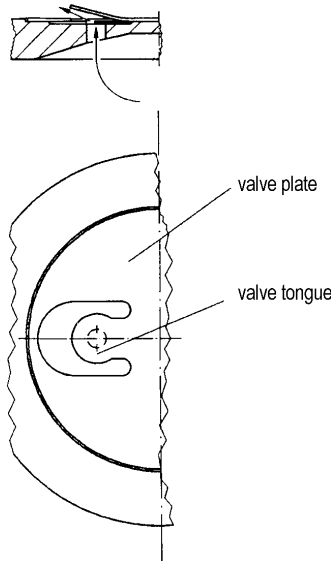

Figure 12: Principle and function of the flapper valves

These must be manufactured from suitable temperature-resistant materials. With diaphragm compressors, because of the high compression temperatures, valve tongues made of spring metal are often used, while in the case of diaphragm pumps for the transfer and evacuation of gases, valves made of elastomers can be used, because of the lower gas temperatures. Elastomer valves are distinguished by their good backstroke tightness.

2.4 Regulation of the flow rate

The regulation of the flow rate may be basically carried out by regulating speed. As most pumps, however, are driven with asynchronous motors, this method is associated with substantial technical requirements.

The flow rate can also be regulated on the pressure side, as well as on the suction side, by reducing the cross-section. When regulating the pressure side, exceeding the permissible working pressure must be avoided. In any case, the diaphragm temperature is increased as a result of the heat of compression. As described in Section 2.7, this has a negative effect on the durability of the diaphragm. Therefore, the better method for reducing the amount transferred is by reducing the cross-section on the suction side. In this case, neither overloading of the diaphragm pump nor higher diaphragm temperatures result. In principle, regulation of the transfer amount via regulating valves is also possible, and for direct current motors, this is achieved by means of regulating the voltage.

2.5 Connections of double-headed pumps

Double-headed diaphragm pumps can be connected in a variety of configurations, according to the desired output profile (Figure 13):

- Heads connected in parallel on the suction side (.1): vacuum and transfer pump for higher flow rate
- Heads connected in parallel on the pressure side (.2): compressor and transfer pump for high flow rate
- Heads connected in series (.3) vacuum and transfer pump for a good vacuum
- Heads connected in parallel on both sides (.1.2): compressor and transfer pump for high pressures

Not all diaphragm pump types are suitable for each of the types of connection listed (see section 3).

2.6 The development of noise

The main source of noise from diaphragm pumps is the diaphragm. As a result of its oscillating movement, not only is kinetic energy transferred to the medium, but it also sets the air in the crank chamber into sound vibration.

Fluttering movements of the diaphragm, as a result of the changing loads on the diaphragm due to negative pressure and over-pressure on suction and compression, produce additional sound emissions, which can be the primary source of noise under unfavorable operating conditions.

With very quiet diaphragm pumps, the drive also represents a significant source of noise. The ball bearings in the drive motor, as well as the vibration of the electric sheet of the stator, cause additional noises. A further source of noise is the valves. Their striking on the seal surfaces as well as the sounds of gases through the small valve openings are responsible for this.

The noises deriving from the diaphragms can be most easily reduced by using a completely enclosed pump housing. This method can only be used with vacuum pumps and very small compressors, because the heat of compression rises during operation allowing the temperature in the non-ventilated pump housing to rise. The increase in temperature in the pump housing reduces the durability of diaphragms and ball bearings (see Section 2.7).

In order to achieve as long a service life as possible for the diaphragms and the drive, the diaphragm compressor and larger vacuum pumps must be equipped with ventilated housings. The noise emissions from the diaphragm described above can be reduced by using the patented SuperSil system (see Figure 14).

In this arrangement, a so-called dampening diaphragm (2) is mounted under the working diaphragm (1). This is tensioned with a part (3) made from elastic material, (e.g., foam rubber), in such a way that the vibrations deriving from the fluttering of the working diaphragm cannot stimulate the dampening diaphragm to resonate together. In this way, the transmission of the fluttering vibrations derived from the drive diaphragm through the air ventilation path, which flows through the pump housing, can be prevented.

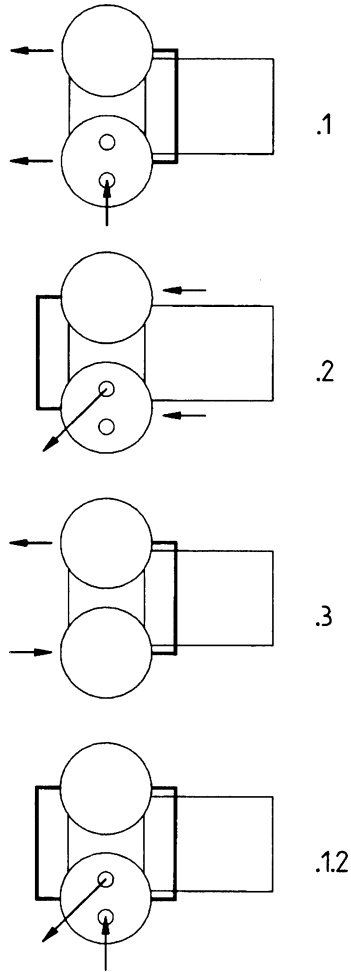

Figure 13: Types of connection of double-headed diaphragm pumps

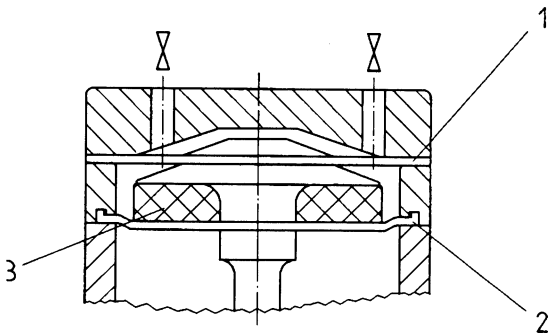

Figure 14: Design of the KNF SuperSil system for reducing noise

The noises coming from the valves can be reduced with small openings in the valve tongues and by low gas speeds.

2.7 Service life of the diaphragm pumps

The service life of the diaphragm pump is determined primarily by the correct constructional layout of the individual components, by the durability of the diaphragm (wearing part), and by the lubricating grease for the ball bearings. To a small extent, in the case of compressors, valves can be counted among the wearing parts, because of their thermal load.

Determining factors for the service life of the diaphragm are:

- the mechanical load, as a result of the stretching upward and downward movement of the diaphragm (see Section 2.3.1)
- working pressure or vacuum
- temperature of the gas to be transferred (see Section 2.3.1)
- temperature in the pump housing
- aggressivity of the gas to be transferred

Regarding the affect of the aggressivity of the gas to be transferred on the service life of the diaphragm, many media in time penetrate into the diaphragm, even when a suitable elastomer (in terms of chemical resistance) is chosen. As a consequence, the diaphragm swells. The then increasing volume of the diaphragm results in the upper dead point (similar to that described in Section 2.3.2, in the 'touching' of the wall of the compression chamber). The diaphragm wears, as a result.

The multitude of parameters that affect service life, which act with different degrees of intensity on the diaphragm, does not allow a clear calculation of the expected service life of the diaphragm. From experience, it can however be stated that a service life of 2000 to 5000 operating hours or more can be achieved without difficulty. This corresponds to $> 1 \times 10^8$ pumping cycles.

While the diaphragm as a wearing part is inexpensive and easy to replace by the pump user, changing the ball bearings is manifestly more complicated. What is important, therefore, is to design the bearing application for a long structural service life. With diaphragm pumps, for the purpose of mounting the drive shaft and the connecting rod mounting, bearing applications filled with lubricating grease and sealed on both sides are used. The life of lithium soap greases is normally about the same as the mechanical life of the bear-

3 Types of diaphragms

3.1 Basic design

3.1.1 Flat diaphragm

The simplest type of diaphragm is the classical, flat diaphragm (Figure 16). It is normally a circular disk made of elastomer strengthened by tissue (see section 2.3.1). Figure 17 shows schematically the mounting of a flat diaphragm in a compressor. The flat diaphragm (1) is wedged on its outer rim between the pump housing (2) and the head component (3). By means of the connecting rod (4), which effects the upward and downward movement of the diaphragm, the flat diaphragm is connected via a rigid metal disk, the retainer plate (5), and a screw (6). In this context, refer to Figure 18.

In the upper dead point of the diaphragm, the 'mushroom' of the connecting rod supports the diaphragm; it therefore exhibits a high pressure-tightness and is not bent on the supported side, under pressure, in the direction of the drive chamber of the pump.

The larger the guide diameter 'd' of the retainer plate, the greater the stroke volume (the theoretically transferable volume per stroke) of the pump. The reason is that the bulging of the diaphragm in the compression chamber (7) (due to the predominating negative pressure in the compression chamber on suction) is decreased with increasing diameter d. However, at the same time, the elastic region L_o , in which the longitudinal stretching takes place, is likewise reduced. On designing a diaphragm pump, the quantities d and L_o , as well as the stroke, with consideration for stretching (see Figure 8), should be arranged in an optimal relationship.

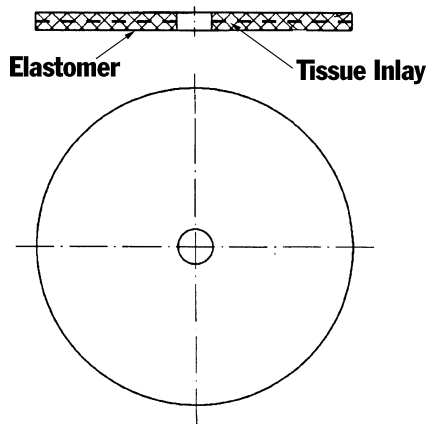

Figure 16: Design of a flat diaphragm

With a stepped retainer plate referred to in Figure 19, the cubic capacity of the pump can be substantially increased. At the same time, the wedging of the diaphragm is only carried out in the region k , as seen in the figure. Thereby, the elastic region L_0 , for a given guide diameter d , is increased by the value L_1 . The amount of stretching can be calculated from:

$$\varepsilon = \frac{\Delta L}{L_0 + L_1}$$

With maximally allowed diaphragm stretching, a substantially greater stroke can be taken advantage of.

Under certain operating conditions, (e.g., a pressure load on a stopped pump), a creeping of the diaphragm out of the outer clamping region and, consequently a deformation of the diaphragm may result. Severe deformation during operation results in the destruction of the diaphragm, as a result of squeezing between the connecting rod mushroom and the wall of the compression chamber (7).

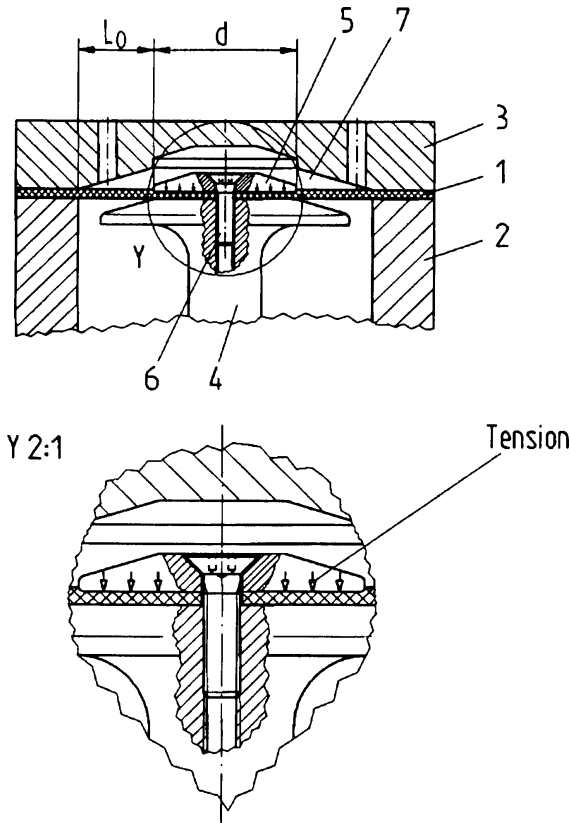

Figure 17: Mounting of a flat diaphragm in a compressor

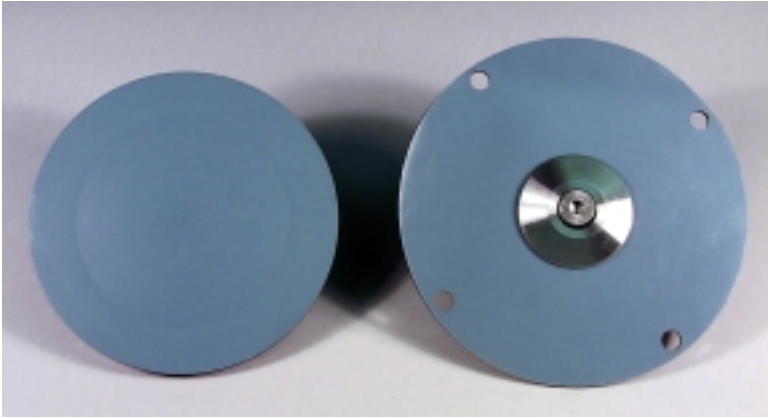

Figure 18: Molded diaphragm and flat diaphragm of same flow capacity.

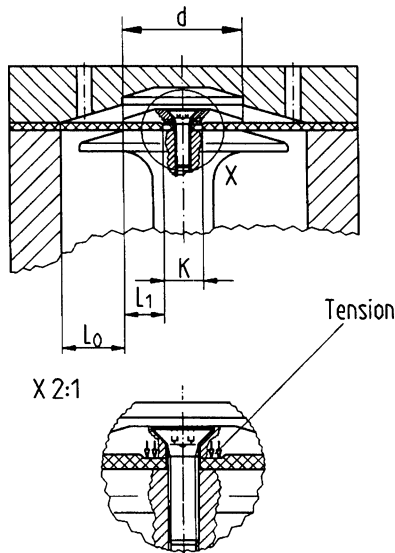

Figure 19: Flat diaphragm with stepped retainer plate: mounting in a compressor

This disadvantage gave the impetus for developing the flat diaphragm with a roll (Figure 20). As a result of the reinforcement, a key-like connection is formed preventing the removal of the diaphragm from the tension region. Especially for high pressures, therefore, only diaphragms of this type are used.

In summary, the advantages and disadvantages of the flat diaphragm construction, including the connecting rod fixing are listed. These advantages are:

- simple and inexpensive component
- less wear
- reliable
- relatively durable
- high pressure resistance, because of the support by the connecting rod mushroom
- high input volume or greater flow rate

Following are the disadvantages:

- a good vacuum is not possible because of the geometric form of the diaphragm, retainer plate and compression chamber, together with the slight tilting movement of the eccentric-operated diaphragm resulting in a large dead volume in the upper dead point of the membrane.
- deficient resistance of the metal components (retainer plate, screw head) in relation to corrosive or aggressive media.

3.1.2 Molded diaphragm

The patented molded diaphragm was developed in order to take account of the desire for still lower ultimate vacuum with diaphragm pumps (Figure 18, middle and Figure 21).

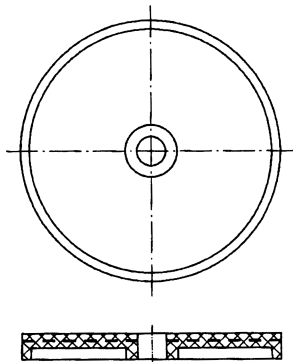

Figure 20: Design of the flat diaphragm with a roll

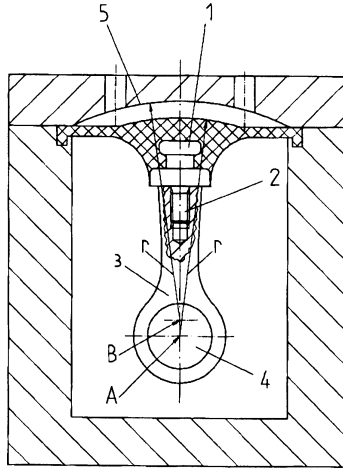

Figure 21: Design of a pump with a molded diaphragm

In contrast to flat diaphragms, molded diaphragms are not screwed using the diaphragm retainer plate and countersunk screw on the connecting rod head, but are fixed by means of vulcanization on a core bolt made of steel (1). The molded diaphragm is screwed on to the connecting rod (3) via the threaded stud of the diaphragm (2). Securing the thread against unintentional loosening is not necessary since the molded diaphragm is firmly secured just as well as the flat diaphragm on the outer diameter between the head and the housing. In that way, it is secured against twisting and cannot be unintentionally loosened. The name molded diaphragm derives from its design form facing the compression chamber. Preferably, a roll is attached in the case of the molded diaphragm on the outer diameter, as described in Section 3.1.1 for flat diaphragms.

An ingenious design of the molded diaphragm minimizes the dead volume in the upper dead point of the diaphragm movement. For that purpose, the elastomer layer with which the core bolt in the region of the compression chamber is covered has the form of a spherical cross-section with a radius r , whose middle point lies in the centre A of the connecting rod bearing (4). The inner wall (5) of the compression chamber is likewise formed as a spherical section with a radius r , whose middle point B lies in the pivotal point of the connecting rod bearing located in the upper dead point. As a consequence of the common spherical shape with the same radius r of the diaphragm surface and the compression chamber, there is no problem relative to starting up or jamming of the diaphragm rising on upward movement. The swivelling movements of the connecting rod and the diaphragm rising on upward movement are neutralized by the centric, sliding into one another, spherical sections. In this way, the molded diaphragm can, in the upper dead point, be moved directly up to

the wall (5) of the compression chamber. The dead space is consequently smaller and the compression ratio is larger. This results in pumps with better maximum vacuum than pumps equipped with flat diaphragms.

When using molded diaphragms, attention should be paid that the diaphragm temperature is not higher than the permissible temperature for the steel-elastomer connection used. With a steel-neoprene connection, this temperature lies around 90 °C. In contrast to flat diaphragms, the molded diaphragm is not supported by the connecting rod in the elastic region; therefore, it is only suitable for over-pressures of up to a maximum of 2 bar.

In relation to flat diaphragms, the molded diaphragm is subject to a significant disadvantage. In contrast to flat diaphragm with a retainer plate, the substantially larger elastic regions of the molded diaphragm bulge in the direction of the compression chamber (as a function of the increasing negative pressure in the compression chamber), and in this way reduce the stroke volume. The suction speed curve of a vacuum pump with a flat diaphragm and that of one with a molded diaphragm are illustrated, for comparison, in Figure 22 (regarding structured diaphragms, see the following Section 3.1.3).

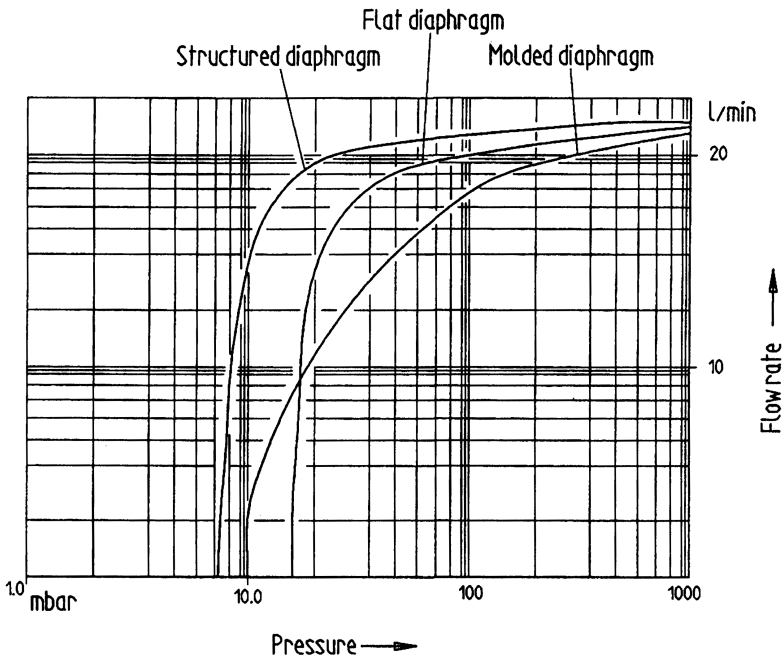

Figure 22: Comparison of suction speeds of pumps with flat diaphragm, molded diaphragm and structured diaphragm

The advantages of the molded diaphragms (including the connecting rod fixing) in overview:

- simple and inexpensive component
- less wear
- reliable
- relatively durable
- enables a relatively good vacuum
- enables a high gas-tightness for the pump because of the closed surface of the molded diaphragm
- reliable, chemical-resistant design is quite possible (for applications with corrosive or aggressive gases or vapors)

The metal part of the diaphragm is covered by rubber; the diaphragm can be coated with protection against media (see Section 3.4).

The disadvantages are:

- limited pressure resistance
- lower flow rate than the flat diaphragm

3.1.3 Structured diaphragm

The aim of the development of the patented structured diaphragm (Figure 18, right, and Figure 23) was to combine the advantages of flat and molded diaphragms and to eliminate their disadvantages, as far as possible. As with the molded diaphragm, the structured diaphragm also has a closed surface facing the compression chamber. In this way, a pump equipped with a structured diaphragm achieves just as good a vacuum as a pump with a molded diaphragm. In order to minimize the bulging of the diaphragm under pressure, the underside of the diaphragm is equipped with a structure of ring zones and ribs, which significantly reduce bulging under a vacuum, without the elastic zone L_o significantly decreasing (for a definition of L_o , see Figure 8). The structuring has the effect that the mechanical load is reduced by about 15% while, at the same time, an improved light running condition is produced.

As a result, a significantly more favorable suction speed curve is produced than that for diaphragm pumps with molded diaphragms and, even more, than that for pumps with flat diaphragms (Figure 22).

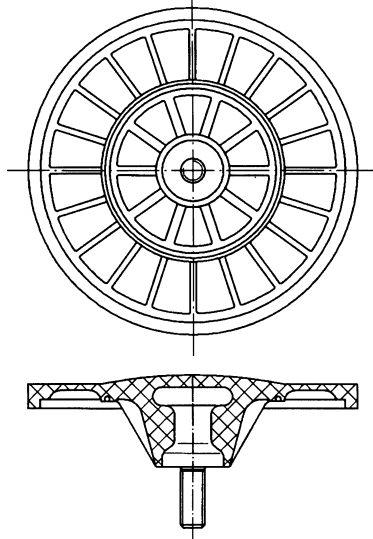

Figure 23: Design of a structured diaphragm

In summary, the characteristics of the structured diaphragm, including connecting rod fixing are:

- simple and inexpensive construction
- less wear
- reliability
- durability
- high pressure resistance in comparison with molded diaphragms
- high input volume or large flow rate
- enables a good vacuum
- design of the pump with reliable resistance to chemicals is quite possible
- enables a clear miniaturizing of the pump.

3.1.4 Summary comparison of flat diaphragm, molded diaphragm and structured diaphragm

	Flat Diaphragm	Molded Diaphragm	Structured Diaphragm
Simple and inexpensive construction	***	***	***
Less wear	**	**	***
Reliable	***	***	***
Durable	**	**	***
High input volume or large flow rate	***	.	***
On compression, high pressure is possible	***	.	**
Enables very good vacuum	.	**	***
High gas tightness	**	***	***
Well suited for reliable chemical-resistant design	0	***	***
Miniaturization	.	**	***

Key: *** very good ** good . relatively good 0 bad

3.2 Other types of diaphragms

3.2.1 Convoluted diaphragm

With very small diaphragm pumps, (i.e., micropumps), there is the possibility of using a special design of the diaphragm for reducing the driving power. In the diaphragms of micropumps, because of the low torque and masses, low lateral directional forces appear guiding the connecting rod or the diaphragm fixing in the horizontal plane. As a result of the low tension load P_F of the diaphragm, latitude to increase the elasticity is produced (for a definition of variables, see Figure 8). In relation to the flat diaphragm, this takes place as the result of the convoluted design of the elastic region L_0 . The increased elastic region induces particularly small deformation forces in the diaphragm during the stroke, and the required power drops. This is particularly interesting for battery-operated micropumps.

Because of the convoluted bulging, even with small lateral forces, the precision of guidance is relatively low. To ensure that during the course of the stroke in the upper dead point neither the retainer plate can strike the wall of the compression chamber nor part of the connecting rod can strike the pump housing, the separation of these parts must be designed to be correspondingly large.

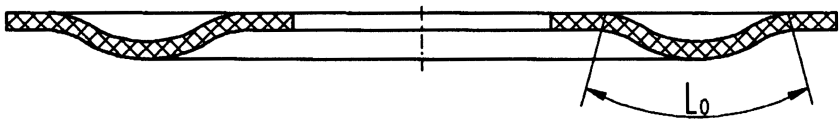

Figure 24: Design of a convoluted diaphragm

Inevitably, a relatively large dead space with corresponding disadvantageous consequences for the maximum vacuum and the flow rate curve is produced.

Convolute diaphragms can only be used in small pumps with low masses and pressure forces.

3.2.2 Wave diaphragm

If hot gases are to be transferred, compressed or evacuated with a diaphragm pump, non-elastic materials such as PTFE are partly used. PTFE has a better temperature resistance than elastomers.

The stretching of the diaphragm required on lift is made possible by means of the geometrical design. The wave diaphragm (Figure 25) makes allowance for this by means of crimps that run around concentric to the center of the diaphragm, which in cross-section appear like waves. These crimps do not allow any precise linear guiding of the connecting rod, so that in this case, as well, a relatively large dead space must be tolerated, with disadvantageous consequences for the maximum vacuum and flow rate curves.

Wave diaphragms made, for example, of PTFE are used when high temperature resistance is required. Elastomers do not have these properties, and the selected material (e.g., PTFE) is non-elastic and requires the 'waves'.

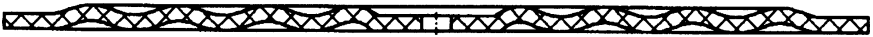

Figure 25: Design of the wave diaphragm

3.2.3 Diaphragm with PTFE coating

The most frequently used diaphragm materials - chlorobutadiene caoutchouc (CR), acrylonitrile-butadiene-caoutchouc (NBR), ethylene-propylene-diene-caoutchouc (EPDM) and fluorocaoutchouc (Viton) - are resistant against different media (Figure 11). Consequently, in practice care must be taken that the diaphragms installed in the pumps are resistant against the respective media to be transferred. Particularly for use in the laboratory this is seen to be troublesome, because the diaphragm pump must be used for many different tasks.

In contrast to standard diaphragm materials, polytetrafluoroethylene (PTFE) possesses a very universal resistance (Figure 11). Flat diaphragms as well as molded and structured diaphragms are, therefore, coated with a thin PTFE layer of ± 0.25 mm for special types of applications. When the elastomer is vulcanized, PTFE is also vulcanized. In this way, the most important properties of the elastomer diaphragm, such as guidance precision, are retained. Diaphragm pumps with PTFE-coated diaphragms can pump practically all media available in the laboratory, as long as all other gas-transferring pump components also have a chemical-resistant finish (see Section 4.3).

4 Special varieties of diaphragm pumps

Because of their specific properties, such as being oil free and having great gas-tightness, diaphragm pumps are suited for a range of special applications. However, some of these tasks place additional demands on the diaphragm. Special varieties have therefore been developed.

4.1 Diaphragm pumps with low leak rates

For the requirements of poisonous or radioactive gases, the leak rate of a standard diaphragm pump of 5×10^{-3} mbar l/sec is not adequate. Traces of the gases in the surrounding air can endanger the operating personnel and the environment. Designs were therefore developed in which the exposed areas are sealed with O rings (Figure 26). With such 'gas-tight' designs, leak rates of 5×10^{-6} mbar l/sec to 5×10^{-9} mbar l/sec can be achieved, depending on the design.

In contrast to the standard design (in which the retainer plate is screwed to the connecting rod by means of a countersunk screw), a thrust screw (1), which is designed as a single part, together with the fixing threaded bolt, (2) is used. Leakages between the screw and retainer plate are in this way eliminated, and no special sealing is required. The O rings (3) take care of tightness at the diaphragm tension sites and valve tension sites. Leakage as a result of gas creeping along the diaphragm, reaching the connecting rod along the threaded bolt where it can escape through porous connecting rod materials can be further prevented by use of the O ring (4). The O ring (4) takes care of this.

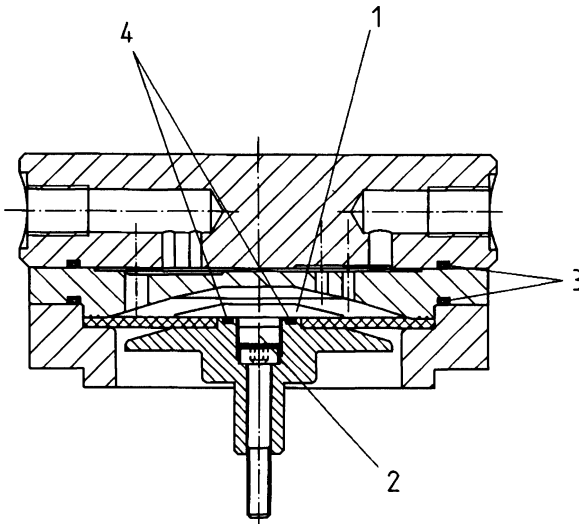

Figure 26: Basic design of the diaphragm pump with a low leak rate.

4.2 Double diaphragm pumps

A potential low leak rate danger exists with the pumps described in Section 4.1. If damage appears on the diaphragm, the poisonous or radioactive gases located in the pump system may reach the outside through the damaged diaphragm. The double diaphragm system (Figure 27) prevents this.

In this case, a safety diaphragm (2) is used in addition to the working diaphragm (1). If the working diaphragm incurs a rupture, the gas located in the pump system can only flow into the innerspace (3); the safety diaphragm prevents escape into the surroundings. The elastic region $L_0 - S$ of the safety diaphragm is larger than the elastic region $L_0 - A$ of the working diaphragm. As a result of the different mechanical loads, the safety diaphragm achieves a greater service life than the working diaphragm. If both diaphragms are exchanged at the same time during the maintenance period and the working diaphragm ultimately ruptures, the safety diaphragm is guaranteed to remain intact and prevent the escape of dangerous gases. The longer service life of the safety diaphragm is further supported by the fact that the safety diaphragm is not burdened by the gases heated by the compression process.

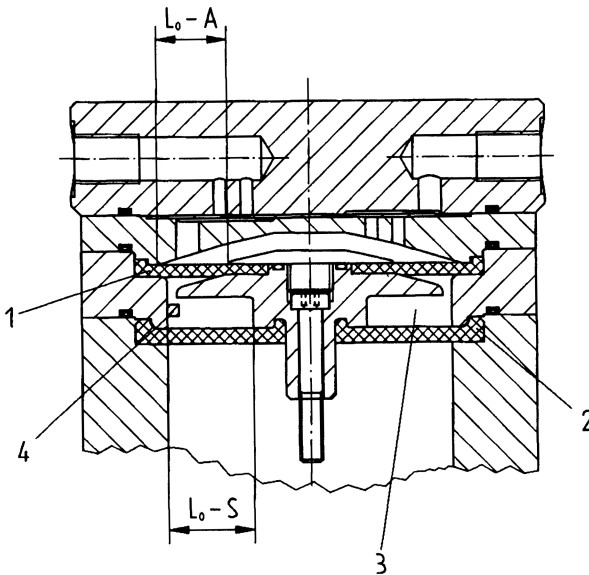

Figure 27: Basic construction of the diaphragm pump with a double diaphragm system

In the event of a rupture of the working diaphragm, a serious drop in pressure or flow rate occurs. In the extreme case, both parameters reach zero. This condition is generally used for monitoring the working diaphragm. If only low

pressures are operated, it is recommended that a pressure sensor (4) be mounted in the innerspace. For this reason, a pressure sensor is to be recommended that reacts to the change in pressure in the innerspace upon rupture of the working diaphragm. Alternatively, a sensor can be used that reacts to gas flowing into the innerspace of the pump system.

When using very expensive gases, for example the isotopes deuterium or tritium, precautionary measures should be taken in order to prevent contamination of the working gas by inflowing air, in the event of a rupture of the working diaphragm. For this purpose, the space between the two diaphragms can be evacuated. On rupture of the working diaphragm, the pressure in the innerspace increases and a mounted pressure sensor indicates rupture of the diaphragm.

Double diaphragm pumps are used in industrial processes, in technochemistry and process engineering, in research as well as in nuclear engineering. A double diaphragm pump with a cut-away section through the pump head and housing (cut-away model) is shown in Figure 28.

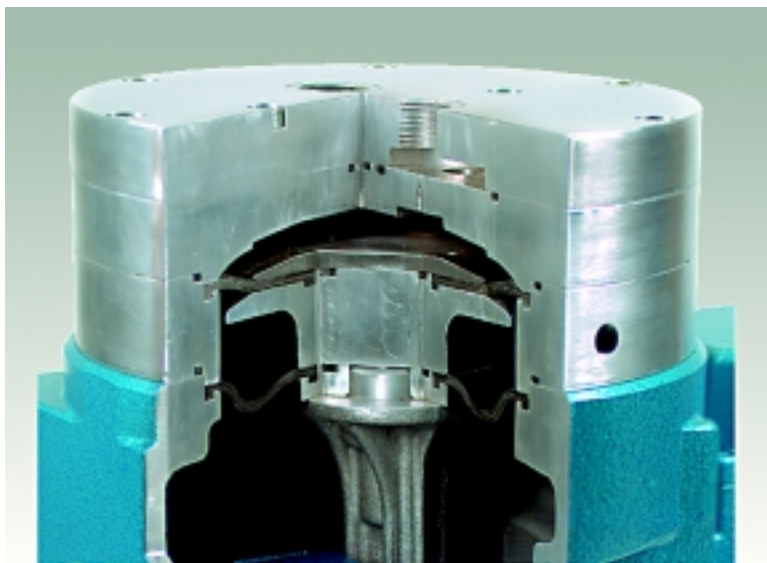

Figure 28: Diaphragm pump double diaphragm system (sectional model)

4.3 Corrosion-resistant diaphragm pumps

Reference to corrosion resistance as a special property of diaphragm pumps has already been made in section 2.2. Section 2.3.1 provides an account of the properties of corrosion-proof diaphragms.

The materials from which the head components that come into contact with gases are made have a significant influence on the quality of the corrosion resistance. The materials are subject to great demands: they should not only be resistant against chemical attack by a variety of media, but should also have the necessary mechanical properties such as high tensile strength and resistance to pressure.

High-grade steels are suitable as head materials. They combine, to a large extent, mechanical and thermal resistance with corrosion resistance. Thanks to their excellent mechanical properties, they can not only be used for diaphragm vacuum pumps, but also for diaphragm compressors. This is of particular importance when high pressures and temperatures arise.

In contrast to plastics, with high-grade steels the suction channel as well as the output channel of the head parts can be equipped with robust threads. Screw joint connections can, in this way, be made with greater resistance to pressure and lower leak rates. Figure 29 illustrates a diaphragm compressor with high-grade steel heads.

Unfortunately, the available high-grade steels, although resistant against a variety of media, are not universally resistant. Therefore, the head material should be selected in each case in relation to the media to be transferred.



Figure 29: Diaphragm compressor with high-grade steel heads



Figure 30: Laboratory diaphragm pump with PTFE heads

A pump with a high-grade steel head is therefore not suitable for every use. For general laboratory use, such a limitation is not acceptable. Laboratory pumps must be suitable for a whole range of uses and media. The most frequent applications are evacuation tasks, such as vacuum filtration or vacuum distillation. Because of the low pressures and the relatively low thermal load, head components made of plastic can be used for laboratory vacuum pumps. Due to its universal resistance against aggressive media, polytetrafluoroethylene (PTFE) has been successfully used (Figure 30: laboratory diaphragm vacuum pumps with PTFE heads). In order to improve mechanical resistance, glass fibers as a filling material are added to the head components made from PTFE. Thereby, success is achieved in controlling the 'creeping' of the head components under pre-stressing up to a head diameter of approx. 150 mm. With large head diameters, on the other hand, leakage may appear. With large pumps, therefore, ceramic is used in place of PTFE parts.

The advantage of ceramic heads lies in their universal resistance to corrosion. The high mechanical durability of the ceramic parts ensures a sure tightness of the pump. The brittleness of the ceramic material requires, however, a careful constructional design of the head components. Otherwise, strain cracks may result. Figure 31 illustrates a diaphragm pump with ceramic heads.



Figure 31: Diaphragm pump with ceramic heads

4.4 Temperature-resistant diaphragm pumps

Because they are free from oil, diaphragm pumps do not contaminate the transferred gases, and because they are gas tight, no loss of gas occurs; they are predestined for use as gas sampling pumps. In many cases, for example, with smoke gases, the gases to be analyzed have relatively high temperatures; sometimes up to over 200 °C. The transfer of such sample gases requires diaphragm pumps that are temperature resistant, and whose diaphragm, valve, and head materials must be suited for these operating temperatures.

As illustrated in Section 2.7, the usable life of grease-lubricated ball bearings drops with increasing temperature. In order to achieve an adequate life in the case of temperature-resistant diaphragm pumps, the head assembly group, including the diaphragm, is elevated with the aid of spacer bolts, from the actual drive with its ball bearings (Figure 32). In the event that porosities are present on the pump housing, a cool air flow will surround the pump housing.

In this way, the ball bearings remain sufficiently cool, even at high temperatures.

When selecting the diaphragm and valve material, the high temperatures that arise should be taken into account. For temperatures of up to 150 °C,

Fluorocautchouc (FPM) can be used. For higher temperatures of up to 240 °C, PTFE has proven valuable. Since PTFE flat diaphragms only allow a small lift, (because of its limited elasticity), wave diaphragms (see Section 3.2.2) are often used.

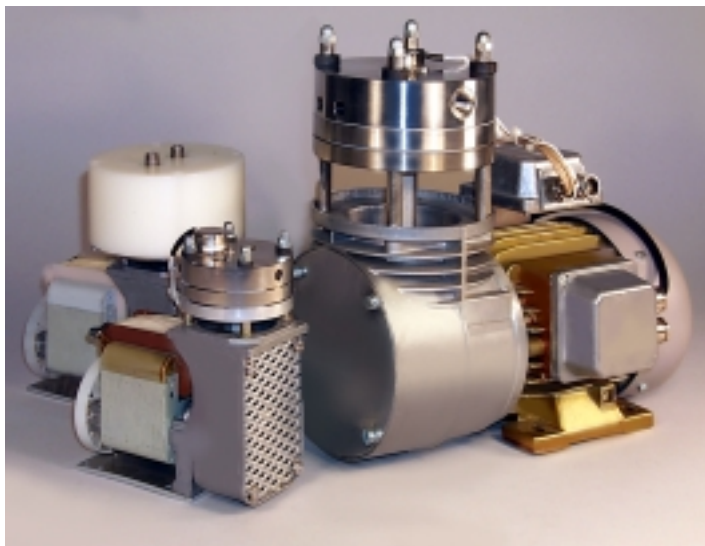

Figure 32: Heated-head diaphragm pump

As head materials for temperature-resistant diaphragm pumps, high-grade steels are generally used because of the high temperatures that arise. They ideally combine temperature resistance with the necessary corrosion resistance. In this connection, attention should be drawn to the fact that aggressive media in a gaseous or vapor state do not attack the materials. Only the condensate, which in the case of non-warmed up or switched off pumps arises from the cooling down of the medium, leads to corrosion. As already mentioned in Section 4.3, high-grade steels are not universally resistant to corrosion. In many areas of application, the gases to be transferred consist, however, of such a spectrum of corrosive media that with the current high-grade steels and, sometimes also with very expensive alloys, safe operation is not guaranteed. For this area of application, temperature-resistant diaphragm pumps with PTFE head components were developed (see Figure 33).

The use of this design is limited to a gas temperature of 200 °C maximum. The PTFE head components (1) are mounted in a subcasing (2) made of aluminum. Thereby, significant creeping of the PTFE at high temperatures is greatly reduced. In order that the tightness of the head assembly group is also guaranteed (despite the indeed minimal, but still present creeping of the PTFE parts) the head components are prestressed by means of head springs (Figure 33, Item 3).

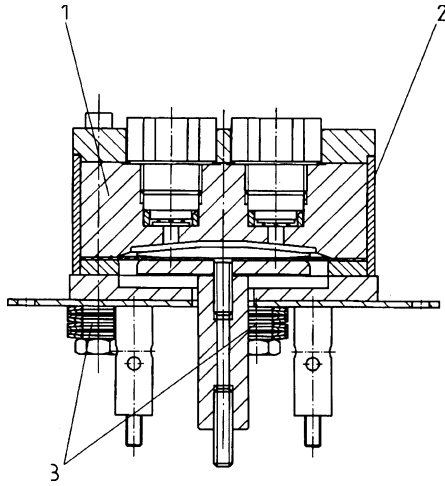

Figure 33: Basic design of the temperature-resistant diaphragm pump with PTFE head components.

4.5 Heated diaphragm pumps

In certain applications, a small cooling down of the working gas leads to a „condensing out“ of parts of the gases, for example with emissions from combustion engines. If the gases are transferred as sample gases, this „condensing out“ distorts the measurement results. In order to prevent condensation, the sample gas is guided via a heated pipeline. The pump head must then also be heated.

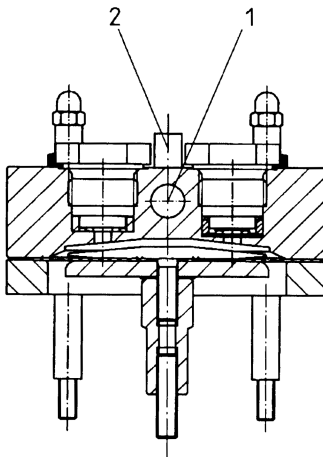

Figure 34: Basic design of the heated diaphragm pump



Figure 35: Heated diaphragm pump with electronic temperature regulation

This is achieved by installing an electric heating element in the pump head (see Figure 34, Item 1). A thermal switch is attached on the pump head that switches off the current supply to the heating element.

There are also designs available in which a temperature sensor is mounted in the head. In this case, the temperature is electronically regulated. Figure 35 pictures such a pump showing the side of the case which contains the electronics. The electrical systems are mainly constructed in such a way that the desired temperature can be regulated.

It can be seen from a comparison of Figures 33 and 34 that the basic design of the heated pumps corresponds to that of the temperature-resistant pumps (the head springs can be identified in Figure 34 on the pump head). Because of the better heat conductivity of high-grade steels, no PTFE head components are used, however, in heated pumps.

5 Appendix: High-speed liquid diaphragm pumps

There is a special type of pump based on the technology of diaphragm pumps with a mechanical drive for transferring, evacuating and compressing gases: the high-speed liquid diaphragm pump. These pumps are used, above all, for the transfer of liquids, but are also used for siphoning off liquids or air-liquid mixtures.

Liquids differ from gases by virtue of their physical properties, which should be taken into account when designing pumps:

- Gases, unlike liquids, can be compressed; that is, liquids do not change their volumes - neither under pressure nor under a vacuum.
- Liquids tend to cavitate: that is, with large drops in pressure, vapor bubbles arise, which collapse again under higher pressure.

These phenomena are considered in the design of high-speed liquid diaphragm pumps by:

- having small diaphragm strokes
- low rotational speeds
- stiffer diaphragms and the use of diaphragm supports (see Point 4 in Figure 36)
- lower compression ratios in the diaphragm compartment
- drive and shaft support being more robustly constructed

The principle of the high-speed liquid diaphragm pumps is illustrated in Figure 36. As with the gas diaphragm pumps, the diaphragm (1) is most often a PTFE-coated rubber element wedged on its outer border by the pump housing (3) and the pump head (2).

Via the eccentric (5), the connecting rod (6) and subsequently the diaphragm are driven. This results in periodic changes in the working chamber and, together with the independent inlet and outlet valves (8), the pumping process. The diaphragm support (4) prevents the diaphragm, on pumping, from sagging against pressure. Figure 37 shows such a pump. The rotational speed of high-speed diaphragm pumps is about 3000 strokes per minute.

The characteristics of the basic design of this type of pump are:

- simple and inexpensive construction
- self-priming, because the pumps also transfer liquid-gas mixtures or gases
- they can run dry since the pumps do not suffer from damage when liquids or gases are transferred
- maintenance-free
- durable and reliable, because of the simple design and robust layout
- chemical resistance: all parts in contact with media can be manufactured from chemical-resistant materials such as PTFE, FFKM or PVDF
- can be operated in every suitable mounting orientation
- compact size
- quiet

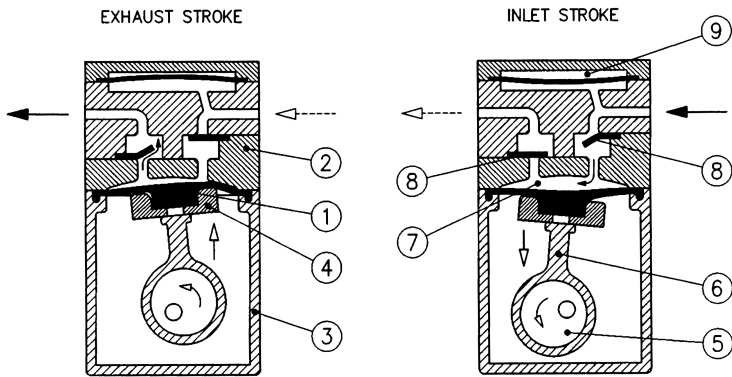

Figure 36: Basic design of the high-speed liquid diaphragm pump

In view of the high number of strokes, the task of preventing cavitation must be given particular attention. This goal is served by the resonance chamber system (see Figure 36); the resonance chamber mounted on the suction side operates like a pulsation damper in that it prevents acceleration peaks in the fluid system on the suction side and, consequently, cavitation. For that purpose, an additional diaphragm resonates in the resonance chamber with the frequency of the working diaphragm (1). When the pump ejects, the column of liquid in the suction region is not abruptly decelerated, but flows in the resonance chamber space. During the subsequent suction cycle, the liquid does not have

to be accelerated from standstill; on the contrary, the pump uses the remaining residual speed.



Figure 37: High-speed liquid diaphragm pumps

The danger of overpressure because the pump operates in a non-desired operating condition (for example, with a blocked pipe or valves that have been closed by mistake) can be countered by an over-pressure relief valve integrated in the pump head. A spring presses a diaphragm against a sealing surface; in this way, a bypass that leads from the pressure side back to the suction side is closed (see Figure 38). When, on the pressure side, the system pressure reaches a set pressure for the over-pressure relief valve, it opens. The medium then circulates via the internal bypass from the pressure to the suction side and back. The required pressure can be simply and precisely set using an adjusting screw.

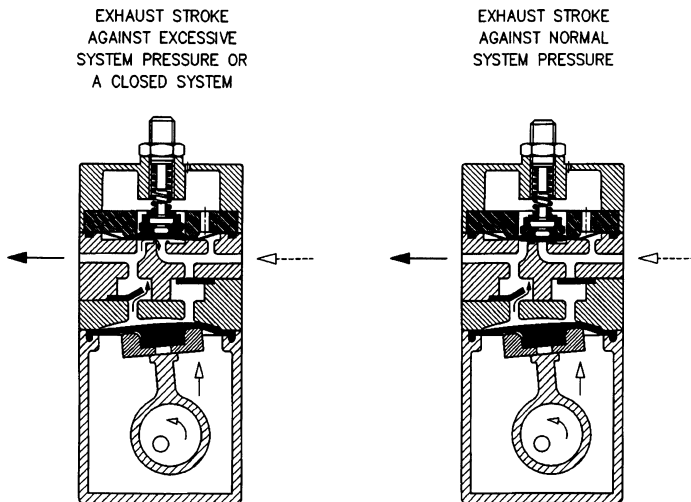

Figure 38: Function of the over-pressure relief valve

With high-speed liquid diaphragm pumps, one can both transfer and meter. Because of the high number of strokes per unit of time, a linear correlation between the number of strokes and the quantity transferred is only conditionally given. Metering does not take place, therefore, via the rotational speed of the motor (as with slowly operated pumps), but as a function of time or the volume of the system. The metering precision of a high-speed liquid diaphragm pump can, however, be substantially increased if a magnetic valve is mounted after the pump or a pressure control valve (that prevents the following of the medium after switching off the pump). In this way, high-speed liquid diaphragm pumps can precisely meter small amounts.

The range of the high-speed liquid diaphragm pumps is:

- Flow rate: up to 6 l/min (measured with water at 20 °C)
- Suction head: up to a 6 m water column
- Pressure head: up to a 60 m water column

6 Applications

The main areas of application for mechanically driven diaphragm pumps for transferring, compressing and evacuation of gases are those in which the special properties of the diaphragm pumps are of importance, individually or in combination.

- Uncontaminated transfer and no contamination of the medium
- High gas-tightness
- High reliability
- High chemical resistance is possible

Important areas of application are in the following spheres:

- Medical technology
- Environmental protection/
- Pneumatics
- Technochemistry/process technology
- Nuclear engineering
- Laboratory
- Electronics analysis technology
- Research

In the following, applications from various spheres of application are listed and explained briefly:

Medical technology

Application	Explanation of the application / Characteristics of the pump
Medical suction equipment	High flow, small construction size, very quiet.
Inhalation equipment	High pressure to flow ratio.
Blood pressure measuring equipment	Small construction size, low current input.
Pulsating cuffs	In order to drain off liquids (e.g., from arms and legs with edema and thrombosis).
Dental ovens	Pump helps to prevent gas bubbles in the material.
Mechanical support of human blood circulation	Support of cardiac activity by means of an intra-aortal balloon pump: a catheter and a balloon are introduced into the femoral artery and positioned in the main artery. The balloon is filled and emptied with gas synchronously with the ECG or arterial blood pressure; this takes place with the aid of a diaphragm pump.
Pneumatically driven artificial heart	The artificial heart used for humans is operated pneumatically with a diaphragm pump.

Environmental protection/analysis technology

Application	Explanation of the application / Characteristics of the pump
Drawing of water samples using a vacuum	Robust system, no difficulty with particles in the water
Measurement of exhaust gas from motor cars	The measurement of the hydrocarbon content of motor car exhaust gases takes place in an ionization measurement procedure using flame ion detectors. For transferring the sample gases, a temperature-resistant pump is used (maximum input temperature of the gas: 240 °C)
Gas analysis for the monitoring of emissions, for use in process control and safety monitoring of room air	Pumps transfer sample gases. Small construction size (for portable measurement equipment as well - see micro-diaphragm pumps, Figure 39), small current input, chemical-resistant design available, heated heads available (in order to prevent condensation)
Mass spectroscopy	Gas samples for the analysis of chemical compounds; only small amounts of sample are necessary.



Figure 39: Micro-diaphragm pump

Laboratory

Application	Explanation of the application / Characteristics of the pump
Evacuation and transferring of aggressive gases and vapors	Use of chemical-resistant pumps with PTFE heads as a substitute for the water jet pump: no water consumption, no waste water, no contamination by waste water; low operating costs
Vacuum filtration	Separation of solid-liquid-material mixtures using the application of a negative pressure on the draining side of a filter
Vacuum rotary evaporator	Lowering of distillation temperature under a vacuum, in order to separate a liquid into its components and to protect from overheating
Drying systems	Degassing of materials under a vacuum.

Technochemistry/process technology

Application	Explanation of the application / Characteristics of the pump
Analysis technology	See above: environmental protection/ analysis technology
Transfer, pumping off, repumping, as well as evacuation and compression of highly aggressive gases and vapors	Pumping using structured diaphragms and resistant materials, reliably chemical resistant
Transfer, pumping off, repumping, as well as evacuation and compression of dangerous or valuable gases and vapors	Greatly increased safety as a result of the KNF double diaphragm system (also see Section 4.2)

Nuclear engineering

Application	Explanation of the application / Characteristics of the pump
Gas sampling pumps	Greatly increased safety, as a result of the double diaphragm system (also see Section 4.2)

Electronics

Application	Explanation of the application / Characteristics of the pump
Circulation guidance of protective gases	Electronics production

Pneumatics

Application	Explanation of the application / Characteristics of the pump
Handling of wafers	Production of electronic chips
Film insertion in x-ray machines	Automatic changing of format
Solder vent	
Pneumatic sealing in airplanes	

Applications for high-speed liquid diaphragm pumps are mainly in the fields of analysis technology, reprographic technology, the cleaning industry, filtration, medical/dental technology, laboratory technology, and water processing.

In analysis technology, liquid diaphragm pumps serve the purpose, for example, of feeding reagents, siphoning of samples and the rinsing or cleaning of the system. For reprographic technology, uses include the feeding, circulating, and siphoning of ink in ink-jet printers or siphoning and pumping off of highly aggressive corrosive liquids with spin etching. Liquid diaphragm pumps are used in the cleaning industry for the feeding and pumping off of liquids in cuvette washers, for the disinfection of endoscopes and in industrial washing machines. Areas of use in the medical/dental technology sphere are, for example, the disinfection of dialysis equipment and dental drills. In laboratory technology, uses include the preparation of tissue samples. Liquid pumps are also used in biochromatography. Sample-taking stations for monitoring water and waste water analysis, in general, are other applications in water preparation.

7 Advice concerning the selection of a pump

Each application has its own requirements that have to be taken into account when selecting a pump. For that reason, the pump must be viewed, not alone, but as a part of a system. Problems can be avoided - unsatisfactory pneumatic power, time delays in the project taking its course, design changes, increased project costs, dissatisfied customers, just to mention a few - if early on in the planning process the most important parameters for the pump are discussed with the manufacturer.

Above all, the following should be considered:

- type of gas
- required pneumatic performance
- gas temperature
- temperature of the surroundings
- other conditions related to the surroundings
- type of motor
- possible constructional parameters
- mounting position and orientation
- operating conditions

Type of gas:

The materials for the pump should be selected according to the type of gas. First, identify whether only a single gas is to be transferred or whether different media are to be used. Then, determine whether they are neutral, slightly corrosive or aggressive gases. If different, aggressive media are transferred, a chemical-resistant pump type is the proper choice.

In addition, the type of gas also determines whether increased gas-tightness is necessary or if a design with a safety diaphragm is required.

Diaphragm pumps for gases are also suitable for vapors, but not for liquids. With compression, care must therefore be taken that in the compression chamber the boiling pressure of the gas is not exceeded. It also has to be clarified whether the medium is inflammable or explosive.

Required pneumatic performance

The very first question that has to be clarified is whether the pump to be selected should serve as a pure transfer pump, solely as a vacuum pump, or exclusively as a compressor. More than one choice is also possible. Then, the desired pneumatic output must be defined. Pumps are generally specified with maximum flow rate, maximum final vacuum and permitted maximum over-pressure. The maximum flow rate is relative to atmospheric pressure; with an increasing negative pressure or over-pressure, the flow rate falls.

In addition to the maximum pneumatic pressure data, the flow curve has also proven to be useful, as for each pressure value (whether a negative pressure or over-pressure), the flow rate can be determined (see the example in Figure 40).

The pump manufacturers cannot, of course, specify the pneumatic requirements of the system in which the pump is to be installed, only the pneumatic performance of their pump. They can only have an influence in this regard. Consequently, when selecting a pump, account should be taken of the tubing, the pump's valves, and any narrow orifices that can affect the performance of the system.

Gas temperature

The temperature of the gas to be transferred determines the selection of the diaphragm material and, in order to protect the bearings at relatively high temperatures from the effect of temperature, the constructional design.

Temperature of the surroundings

In order to guarantee problem-free operation of the pump over a very long period of time, the temperature of the surroundings is a factor that has to be taken into consideration.

Other conditions related to the surroundings

If the pump surroundings are endangered by the risk of explosion, the question of whether the pump should be used at all should be examined. If a pump is required, a pump with a drive motor that is protected against explosion must be selected. Other questions concerning the surroundings relate to dust and moisture, whose presence may also affect the type of protection required for the pump's drive motor.

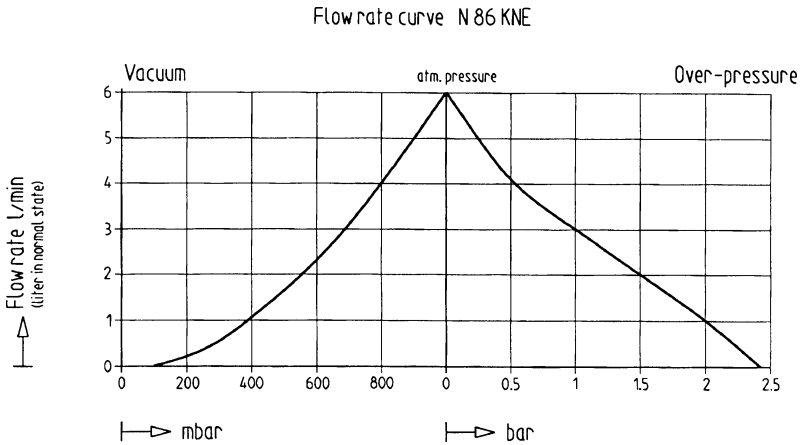

Figure 40: Example of a flow rate curve for a diaphragm pump

Types of motor

It must be determined whether the equipment or unit in which the pump is to carry out its work will be driven by alternating current, direct current or three-phase current. Which voltage is available in the system? With alternating current, frequency also plays a role.

Possible constructional parameters

What location is available for the pump in the system? In this regard, consideration must be given to the necessary distance of the pump from other components in order to ensure the cooling of the drive motor.

Mounting orientation

With some exceptions, diaphragm pumps with eccentric-driven diaphragms for gases can be operated in all mounting orientations. Generally, it is recommended to mount the pump at the highest position in the system, in order that any condensed liquid which may possibly result does not collect in the pump head and affect pump operation.

Operating conditions

Is the pump to be operated continuously or at intervals? If it is to be operated at intervals, at what cycle? Other important aspects relate to starting the pump. For most pumps (for reasons of cost and in order to keep energy consumption low) the drive motor is designed so that the pump cannot start against pressure

or a vacuum. If, however, such operation is desired, one should select the appropriate type of pump. Finally, operating conditions also affect the choice of a design requiring increased gas-tightness or a safety diaphragm.

If the aspects mentioned above are taken into account at an early stage of system design, the trouble-free operation of the pump will be ensured for a long period of time. For that reason, there are a multitude of pump designs available for selection, thanks to a modular system of pump materials and drive motors. Not all possibilities can be covered by standard pumps. With simple modifications, however, exceptional requirements can be fulfilled.

8 References

[1] Albert Neuburger: "Die Technik des Altertums", P. 50

[2] "A History of Technology", Edited by Trevor I. Williams. Volume VI: The Twentieth Century c 1900 to c 1950 Part 1, P. 506

[3] Trevor I. Williams: "A Short History of Twentieth Century Technology: c 1900 - c 1950", P. 145.

[4] Andreas Hofer Hochdrucktechnik.

9 Bibliography

A History of Technology, Edited by Trevor I. Williams. Volume VI: The Twentieth Century c 1900 to 1950, Part 1, Oxford, Clarendon Press, 1978.

Andreas Hofer Hochdrucktechnik, *Produktunterlagen Membran-Kompressoren*. Becker, Erich: *Vom Blasebalg zur Membranpumpe: Entwicklungen an der Membran brachten den Durchbruch*, in *Chemie Technik*, Volume 1/1997, p. 62-66.

Bolt, Erwin: *Fördern und Dosieren mit schnellaufenden Membran-Flüssigkeitspumpen*, in *wägen und dosieren*, 2/1997, p. 29-33.

Carl Freudenberg Dichtungs- und Schwingungstechnik KG, *Membranen als Konstruktionselemente*, Weinheim, 1994.

Carl Freudenberg Dichtungs- und Schwingungstechnik KG, *Simrit Standardkatalog*, Weinheim.

Dehnen, M: *Membranverdichter*, in Vetter, G (ed): *Leckfreie Pumpen und Vedichter*, 2nd Edition, Essen: Vulkan Verlag, 1992, p. 202-215.

Dickenson T.C., *Pumping Manual*, 9th Edition, Oxford, Elsevier Advanced Technology, 1995.

Hauser, Erwin: *Motivationsprogramm: Verbesserte Membrandruckscheibe erlaubt kompaktere und leistungsfähige Pumpen*. Offprint from konstruktionspraxis Nr. 9, September 1990.

Neuburger, Albert: *Die Technik des Altertums*, Leipzig, Voigtländer Verlag, 1919; reprint Leipzig, 1980.

SKF GmbH: *SKF Hauptkatalog 4000/IV T*, Schweinfurt.

Williams, Trevor I., *A Short History of Twentieth Century Technology: c 1900 - c 1950*. Oxford, Clarendon Press; New York, University Press, 1982.

Winnacker and Küchler, *Chemische Technologie*. 4th Edition, Volume 1, Allgemeines. Munich, Vienna, Carl Hanser, 1984.

WISA: *Romega, Kommentar zu den technischen Daten von WISA und Romega Membranpumpen: Einsatzhinweise zur Förderung der Lebensdauer und Angaben zu den Leistungsgrenzen der Membranpumpen.*, Wilhelm Sauer GmbH & Co. KG.

Wutz, Max; Adam, Hermann; Walcher, Wilhelm: *Theorie und Praxis der Vakuumtechnik*. 3, revised and supplemented edition. Braunschweig, Wiesbaden, Friedr. Vieweg & Sohn, 1986.

In addition, numerous documents from KNF Neuberger GmbH, Freiburg im Breisgau (Germany), were used, as well as documents from KNF FLODOS AG, Sursee (Switzerland).

Author: Mr. Erich Becker, Mechanical Engineer, upon completion of his degree, was employed as a designer in the vehicle and machine tool industries. Since 1962, Mr. Becker has had a major impact in the development of mechanically driven diaphragm pumps for gases.

Mr. Becker has developed many patented solutions for his company, KNF Neuberger, which has grown to a worldwide operating group specializing in gas and liquid pumps.