



## Fine Powder Flow Phenomena in Bins, Hoppers, and Processing Vessels<sup>1</sup>

by  
T. Anthony Royal  
and  
Dr. John W. Carson

### ABSTRACT

Fine powders often exhibit significant two-phase (solid/gas) interactions when they are handled in bins, hoppers, and processing vessels. As a result, numerous and more complex flow problems can occur which are not observed with larger particle bulk solids.

The powder's flow pattern has a major effect on the development of certain flow problems, especially flooding. This can usually be overcome by using mass flow designs. Unfortunately, when mass flow is achieved the powder's discharge rate through a hopper outlet may be severely restricted.

These phenomena are explored along with related topics such as:

- Steady flow phenomena in bins and hoppers
- Air permeation systems
- Unsteady flow phenomena (*e.g.*, settlement)
- Fluidized handling of powders

### 1. TYPICAL FINE POWDER FLOW PROBLEMS

Many bulk solids exhibit one or more of the following flow problems:

- *No flow* due to arching or ratholing
- Particle segregation
- Limited live or useable capacity (usually the result of a ratholing problem)
- Degradation (spoilage, caking, oxidation) which is usually the result of a first-in-last-out flow pattern
- Structural failure of bins due to loads being applied to them which they were not designed to withstand

Materials for which the mean particle size is less than, say, about 100  $\mu\text{m}$  (termed a *fine powder* in this paper) can also exhibit the following additional flow problems:

- Flooding or uncontrolled flow which is often the result of a collapsing rathole in a funnel flow bin

---

<sup>1</sup> Source: Royal, T. A. and Carson, J. W.: Fine Powder Flow Phenomena in Bins, Hoppers and Processing Vessels. Presented at *Bulk 2000: Bulk Material Handling Towards the Year 2000*, London, 1991.

- Limited discharge rate through a bin's outlet
- Unsteady flow phenomena such as settlement as the powder is charged into a bin

## **2. HOW FLOW PATTERNS AFFECT FLOW PROBLEMS**

### **2.1 Funnel flow bins**

When a fine powder is stored in and discharged from a bin having a *funnel flow* pattern, ratholing and flooding problems are almost inevitable. The reason for this is that when a powder becomes deaerated in the stagnant region of a funnel flow bin, it usually develops sufficient cohesive strength that its *critical rathole diameter* (the flow channel diameter at which a rathole becomes unstable) is larger than the size of a flow channel which might reasonably develop. (1) Thus a rathole develops whose diameter is approximately equal to the diameter of the flow channel. In the case of a funnel flow bin with a circular outlet, this is roughly equal to the outlet diameter. A funnel flow bin having a square or rectangular outlet will tend to develop a circular flow channel (and resulting rathole) whose diameter is approximately equal to the length of the diagonal of the outlet.

When a rathole develops in a funnel flow bin, *e.g.* as the bin level drops when the in-feed rate is slower than the discharge rate, a condition is set up which can lead to flooding. The scenario is as follows: Since the sides of a rathole are often relatively unstable, the rathole occasionally collapses due to ambient vibrations in the plant, restart of filling of the bin, or someone hitting on the sides of the bin. When this happens, the fine powder drops through a column of air (or whatever gas is in the bin) causing the particles to become fluidized. Most bin feeders (*e.g.* screws, belts, vibrating pans, rotary valves) are generally designed to handle a

solid, not a fluid. Thus when this fluidized material reaches the outlet, it often flows uncontrollably resulting in what is termed *flooding*.

A similar phenomenon can occur in a funnel flow bin even if a rathole does not develop. The reason for this is that the narrow flow channel provides only a short residence time for material entering the bin. Since this material is often in a fluidized state just due to falling into the bin or coming from a pneumatic conveying line, it has only limited time to deaerate which can also result in a flooding condition at the outlet.

### **2.2 Mass flow bins**

Flooding and ratholing problems can be overcome by using bins having a *mass flow* pattern. While this is always a significant improvement in the handling of fine powders, it is not without problems of its own. Arching over the outlet may still occur, as with a funnel flow bin, although it is less likely because of the steeper and less frictional hopper walls. The other problem that can occur is one of limited discharge rate through the bin outlet. It may seem strange that the same fine powder which can flood through an outlet uncontrollably in a funnel flow bin can, at the same time, flow through a mass flow bin at a rate which is lower than desired for process requirements. The reasons for these phenomena will be described below.

### **2.3 Segregation**

Fine powders can also segregate, usually by one of two mechanisms: (2)

- *Fluidization* (air entrainment) which often results in vertical striations within a bin. The larger and/or denser particles become concentrated below the finer and/or lighter particles.

- *Particle entrainment* in an air stream which can result in unusual segregation patterns depending on where particles drop out of suspension.

As with larger particle materials, fine powders can exhibit significant levels of segregation as they discharge from a funnel flow bin. This is the result of the segregation pattern, which develops as the bin is filled, combined with the first-in-last-out flow pattern of a funnel flow bin. Unlike coarser particle material, however, many fine powder segregation problems cannot be overcome by simply converting to a mass flow pattern. This is particularly true of fine powders that segregate by the fluidization mechanism. In fact, since materials discharge from a mass flow bin in a first-in-first-out flow sequence, the effect of a vertical striation profile can be much worse than experienced in a funnel flow bin. Fortunately there are ways that this can be minimized, *e.g.* by charging the material into the bin in such a way that the larger and/or more dense particles are not driven down into the bed of material.

### **3. STEADY FLOW PHENOMENA IN MASS FLOW CONTAINERS**

The maximum flow rate of a fine powder through a bin outlet can be several orders of magnitude lower than that of a coarser particle material. The primary reason for this limitation is the air pressure gradient that forms naturally at a bin outlet as air flows up into the hopper section. This pressure gradient acts upward, counter to gravity, thus reducing the rate of material discharge. The magnitude of the pressure gradients is very low with coarser particle materials because they are more permeable. In other words, air can easily flow through their voids without resulting in much of a pressure drop.

Fine powders exhibit significant two-phase flow effects due to the movement, however slight, of interstitial gas as the powders compress or expand during flow. The following is a description of the three flow-rate dependent modes that can occur in a mass flow bin, depending on the solids flow rate.

1. The first mode of flow is characterized by the steady gravity flow of partially deaerated material controlled by a feeder. The limiting steady-state condition occurs when compaction in the cylinder forces too much gas out through the material top surface. This causes a slight vacuum to form as the material expands while flowing through the converging portion of the bin. The result is a gas counterflow through the bin outlet, which forces the solids contact pressure to drop to zero and limits the *steady* solids flow rate.
2. The second mode occurs at flow rates somewhat greater than the limiting rate. This mode of flow is characterized by an erratic, partially fluidized powder discharging from the bin, which can be controlled by some feeder arrangements. At these flow rates, a steady rate from the bin can best be achieved by the use of an air permeation system at an intermediate point in the bin to replace the lost gas.
3. The third mode of flow occurs when the flow rate is too high to allow much, if any, gas to escape from the material voids. In this extreme, the material may be completely fluidized and flood through the outlet unless the feeder can control fluidized solids.

Testers are available to measure the *permeability* (3) and *compressibility* (4) of powders and other bulk solids. From such tests one can calculate critical, steady-state flow rates

through various outlet sizes in mass flow bins. With this information, an engineer can determine the need for changing the outlet size and/or installing an air permeation system to increase the flow rate. Furthermore, one can determine the optimum number and location of air permeation levels, and estimate the air flow requirements.

### 3.1 Example

The types of conditions which can occur are best illustrated by means of an example. Using a proprietary, two-phase flow computer program (5) we have analyzed the bin shown in Fig. 1. For this analysis we have assumed that this mass flow bin is filled with a dry sludge powder having the following flow properties:

- Wall friction angle:

- 35° along carbon steel walls in cylindrical section
- 20° along 304 2B surface finish stainless steel walls in conical hopper section

- Minimum outlet diameter to prevent arching in a mass flow bin: <75mm
- Effective angle of internal friction:  $\delta = 50^\circ$
- Bulk density/consolidating pressure relationship:

$$\gamma = \gamma_0 \left( \frac{\sigma}{\sigma_0} \right)^\beta$$

- where:  $\sigma_0 = 0.62 \text{ kPa}$   
 $\gamma_0 = 0.577 \text{ tonne/m}^3$   
 $\beta = 0.05$

- Permeability/bulk density relationship:

$$K = K_0 \left( \frac{\gamma}{\gamma_0} \right)^{-a}$$

- where:  $K_0 = 0.00335 \text{ m/sec}$   
 $a = 6.4$

- Minimum bulk density:  $0.545 \text{ tonne/m}^3$
- Specific gravity of a particle: 1.29

When one analyzes these values of wall friction angle, effective angle of internal friction, and hopper angle, the Jenike theory (1) indicates that a mass flow pattern will develop.

### 3.2 Effect of different levels of powder

For steady flow into and out of the bin at a rate of 7 tonne per hour, Fig. 2 shows the resulting interstitial air pressure distribution which develops while maintaining the cylinder full,

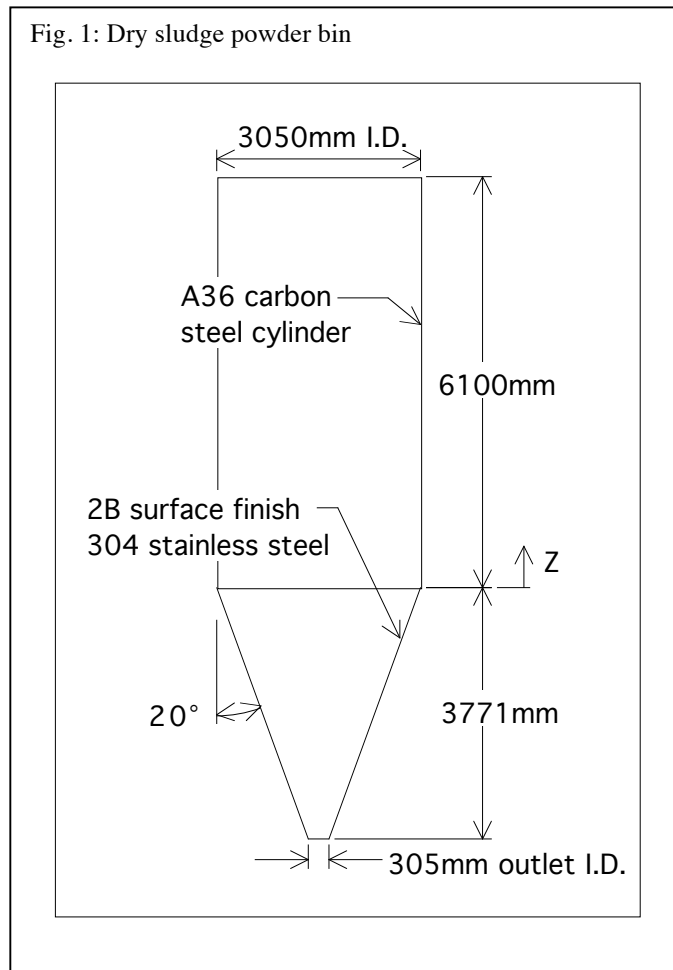
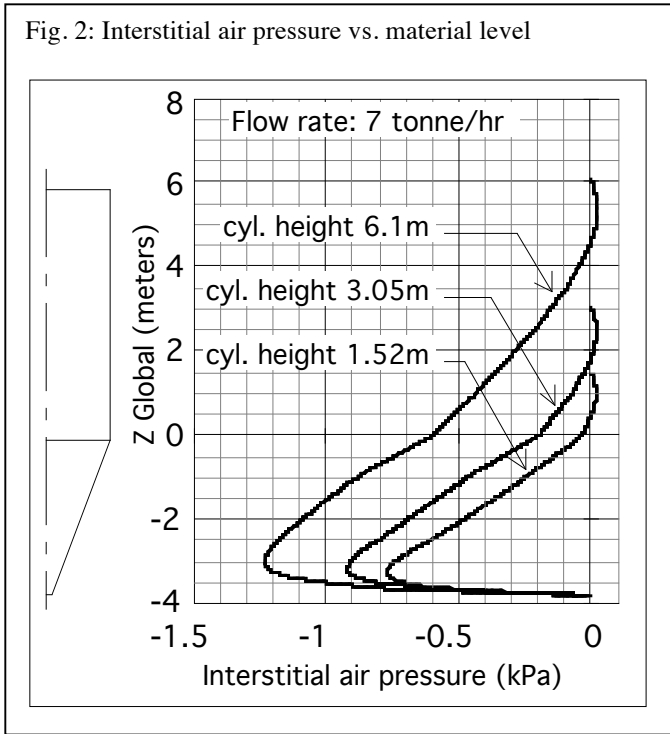

Fig. 2: Interstitial air pressure vs. material level



half full, or quarter full of material. This is for boundary conditions of atmospheric pressure at both the top of the bin as well as the outlet. Note that just above the outlet, an air pressure gradient due to upward flow of air exists which tends to reduce the average vertical solids contact stress in this region. The limit is when this solids contact stress goes to zero which indicates the formation of a free surface, *i.e.* an arch.

The calculated air pressure gradients and solids contact stresses at the outlet for the different levels in the bin are as follows:

Material level in cylinder	Air pressure gradient divided by bulk density	Average vertical solids contact stress
Z, m	$\frac{dp/dz}{\gamma}$ , dimensionless	$\sigma_v$ , kPa
1.52	-1.13	0.106
3.05	-1.22	0.067
6.10	-1.31	0.032

Note that the air pressure gradients are negative which indicates that they act upward, counter to flow of the powder. Their magnitudes are higher for higher levels of material which leads

to lower solids contact stresses at the outlet. This is because the material is compacted more in the cylinder at high levels, the longer retention time allows more gas to escape through the top, and so more air must enter through the bottom as the powder flowing towards the outlet expands.

In fact, calculations reveal that if the cylinder height were increased to 9.4m, the average vertical solids contact stress would approach zero. For this level of material or higher, we expect that flow would be unstable at the desired rate of 7 tonne per hour.

### 3.3 Effect of outlet size

A similar result is shown in Fig. 3 in which the same 7 tonne per hour discharge rate is used with a full cylinder but now three different outlet diameters are shown: 457 mm, 304 mm, and 203 mm. Note that as the outlet becomes smaller, the magnitude of the air pressure gradient near the outlet increases; therefore the solids contact stress decreases. In fact, a limiting rate will occur for the smallest opening size.

Fig. 3: Interstitial air pressure vs. outlet size

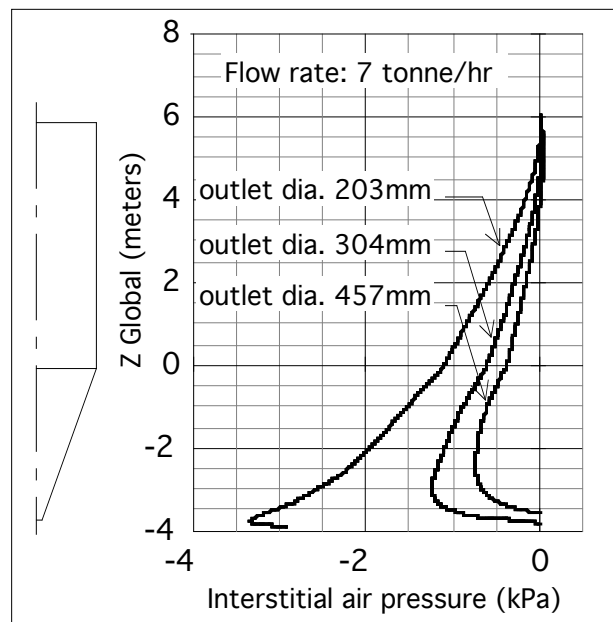
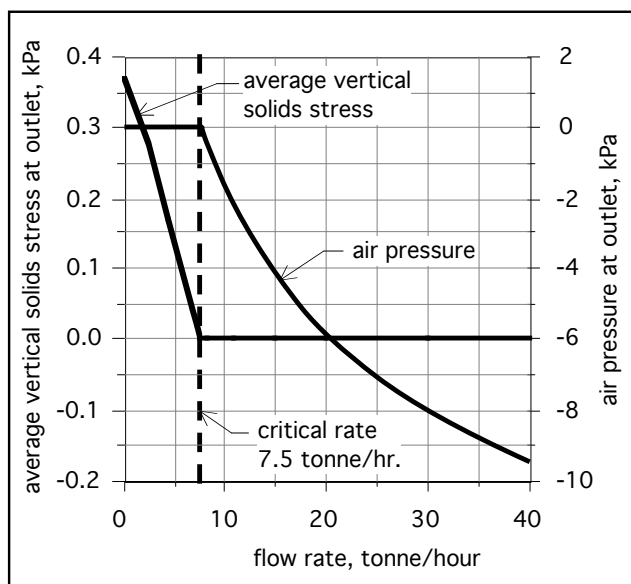

Fig. 4: Average vertical solids stress and air pressure at outlet vs. flow rate



### 3.4 Effect of powder flow rate

The results of a number of runs are shown in Fig. 4. Here we have assumed a full cylinder of material and a 305 mm diameter outlet. This figure vividly demonstrates the effect that flow rate has on both interstitial air pressure and solids contact stress. Note that below 7.5 tonne per hour, the bottom boundary condition of atmospheric gas pressure can be met. Above this rate we have an unstable flow condition since the solids contact stress goes to zero. The only way that this boundary condition can be satisfied is to have a vacuum condition existing at the outlet.

One way to correct this problem would be to increase the size of the outlet as shown in Fig. 3. However, there is a limit to how large the outlet can be and still be reasonable in terms of the size of a feeder, which might be used to control the discharge rate, or the size of interfacing equipment.

Another way to correct this would be to use a standpipe below the outlet but above the feeder.

Fig. 5: Effect of air permeation system

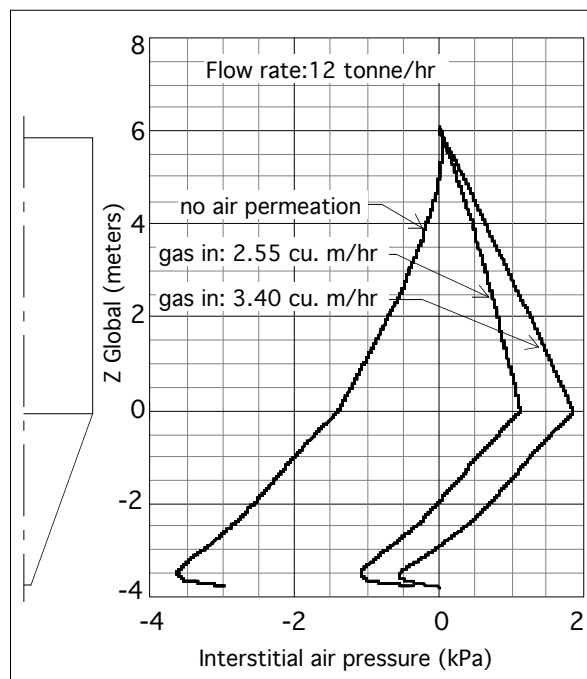

However, there is a limit to the amount of vacuum that can be maintained in the standpipe.

The most effective way this flow rate limitation could be overcome is through the introduction of a small amount of air using an air permeation system (7,8) as shown in Fig. 5. The location as well as the quantity of air must be closely examined; otherwise too much or too little air may be added which will cause either a flooding condition or will not be sufficient to achieve the desired flow rate. As shown in Fig. 5, the addition of 2.55 m<sup>3</sup>/hr or 3.4 m<sup>3</sup>/hr at the transition results in stable flow.

The other area of interest is when the flow rate is very high. In this case material does not have time to deaerate in the bin and remains fluidized. Handling fluidized materials is discussed below.

## 4. UNSTEADY FLOW PHENOMENA

### 4.1 Firing of an air blaster

In addition to the steady flow phenomena described above, fine powders can exhibit various types of unsteady flow phenomena as

well. For example, when an air blaster is fired or a vibrator turned on, material flow is likely to be unsteady for some brief period, as previously nonflowing material starts to flow. A similar phenomenon occurs with coarser bulk solids as well. The effects of this energy input, however, are often quite different with a fine powder, especially when an air blaster is fired into a bin. With both a fine powder and a coarse bulk solid, a solids stress wave propagates through the material. If the material is very compressible and/or frictional, the effect of the stress wave is dissipated quickly.

Another effect is an air pressure gradient imposed on the bulk solid because of the introduction of excess air. For a fine powder this pressure gradient can be several orders of magnitude higher than for a coarse bulk solid. The magnitude of the air pressure gradient imposed is approximately proportional to the square of the distance from the blaster. As a result, an air blaster is often more effective in breaking arches that occur near its nozzle, but less effective in breaking arches that occur some distance away. Detailed computer calculations based on the flow properties of the material are necessary for determination of number, size, and location of air blasters in a particular bin. (5)

## 4.2 Settlement

Another interesting unsteady phenomenon with fine powders is that of *settlement*. (9) Nearly all bulk solids settle as they are filled into a container because of the vertical compression of the material lower in the container as new material is added on top of it. With coarse bulk solids, the amount of settlement is usually quite small, and as soon as filling is stopped, there is little if any additional settlement. A fine

powder behaves quite differently both in the amount of settlement as well as its duration. The reason for this has to do with the inability of air and other gases to flow freely through the voids of fine powders. Therefore, when a fine powder is compressed (such as when it is being filled into a container), not only do the void spaces shrink, but the gas pressure within the voids increases. Thus, during filling, an upward gas pressure gradient continually exists which tends to support the fine powder and limit its compaction. At the end of the filling cycle, this upward gas pressure gradient is still present and gradually dissipates over time as the gas escapes through the top surface. Thus, the settlement of a fine powder takes place much more slowly than that of a coarse bulk solid and, in general, the amount of settlement is much greater. In fact, it is not unusual to find a fine powder experience 300 mm or more of settlement which occurs over several days or longer after the filling cycle has ended.

As an example of this phenomenon consider the bin shown in Figure 1 for storage of dry sludge powder having the same flow properties as previously given. The question is how fast the bin can be filled and how soon it can be used after filling without encountering flooding due to the material being somewhat fluidized in the bin. Figure 6 gives the results of calculations for a fill rate of 91 tonne/hr. and 455 tonne/hr. As can be seen, the air pressure in the voids of the solids increases during filling and then dissipates over time as the air escapes through the top surface and settlement occurs. The pressure after filling is sufficient in both cases to cause problems with feeders not designed to handle material in a fluidized state. However, in both cases this pressure is completely dissipated after about 40 minutes.

In the case of the 455 tonne/hr. fill rate, the maximum air pressure at the bottom of the cylinder is 11.9 kPa and the top surface settles down 245 mm as the air escapes. At 91 tonne/hr., the maximum gas pressure is only 3.2 kPa and the material settles only 45 mm.

The phenomenon of settlement becomes more pronounced with taller bins handling finer, less permeable, and more compressible materials. It can also be important in loss-in-weight hoppers, where extremely high fill rates are required to minimize the amount of time the hopper is in a volumetric mode.

### 5. FLUIDIZED HANDLING OF POWDERS

Sometimes it is more practical to handle fine powders in a fluidized state rather than to allow them to deaerate and try to handle them by gravity alone. Through the use of air pads, air slides, and/or air nozzles, some or all of the contents of a bin can be fluidized. Such material cannot form a stable arch or rathole. In addition, fluidized material will discharge through a bin outlet several orders of magnitude faster than a deaerated fine powder.

Some of the considerations involving fluidized handling are as follows:

1. The bulk density of the fine powder upon exiting the bin will be low and non-uniform. Thus if the material is being used to fill another container (*e.g.* a truck or rail car), it may not be possible to fit the required mass of material into that container. If, on the other hand, the material is going into a process where close control of flow rate is important, the non-uniformity of bulk density may create major control problems.
2. The cost of energy required to fluidize the bin may not be insignificant. This is

Fig. 6A: Settlement of material vs time

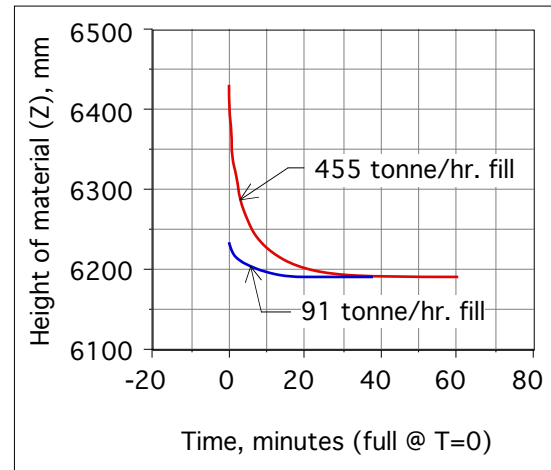
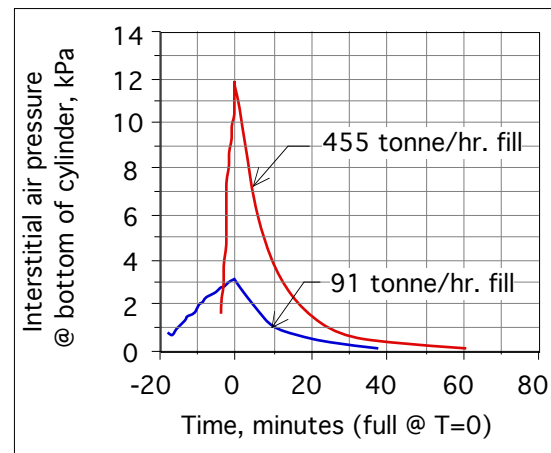

Fig. 6B: Air pressure vs time



particularly true if dry air must be used because the material in the bin is hygroscopic.

3. Particle segregation may be improved or made worse through the introduction of air. While there are some blenders on the market which use air as the motive force to blend materials, simply putting an air pad or an air slide into a bin is more likely to segregate a fine powder rather than blend it, especially if the material segregates by the air entrainment (fluidization) mechanism. Fines end up on the top and more dense or larger particles end up on the bottom.

4. It is not always clear how much of the bin volume needs to be fluidized. It is generally best to fluidize the entire contents of the bin, but this may be neither practical nor necessary if the bin is relatively large. If only a portion of a bin is fluidized, one must be concerned about the potential for a rathole forming in the deaerated material outside of the fluidized volume. In addition, void space must be provided for the material to expand.
  5. Another concern is how long to leave on the fluidizing air. This question is important not only during discharge, but more importantly, when there is no discharge taking place. Fine powders, which are cohesive when deaerated, become very difficult to refluidize after they deaerate. If this is the case, intermittent fluidization during periods of no discharge may be necessary.
3. Ensure that the design of the feeder is compatible with that of the bin so that the full area of the outlet is *live*.
  4. Whenever a pneumatic conveying line terminates at a bin, arrange the interface such that the material enters the bin tangential to the cylinder wall. While this may result in some side-to-side segregation of particles, it will minimize any top-to-bottom striations, which are difficult to overcome.
  5. Based on the permeability and compressibility of the powder, calculate the critical, steady-state flow rate through the bin outlet. If possible, operate the feeder such that the discharge rate from the bin is always less than this critical rate.
  6. If a higher discharge rate is needed, enlarge the size of the outlet and feeder, lower the level of material in the bin, and/or use an air permeation system.
  7. Place a standpipe between the outlet of a bin and the feeder to create a vacuum condition at the outlet. This will result in somewhat higher rates of material discharge.
  8. Beware of the settlement time of powders when placed in a bin. If sufficient time is not allowed for settlement, problems of flooding through the outlet can occur because of entrapped gas.
  9. Use fluidized handling of powders if the material characteristics and operational requirements allow it.

## **6. SOLUTIONS TO FINE POWDER FLOW PROBLEMS**

Fine powder flow problems can usually be minimized if not eliminated by using one or more of the following techniques:

1. Use bins designed for mass flow rather than funnel flow. This will automatically eliminate problems of ratholing, limited live capacity, and the first-in-last-out flow pattern, which often causes degradation of the powder being handled. In addition, mass flow designs minimize particle segregation problems provided the segregation pattern within the bin is of a side-to-side as opposed to a top-to-bottom type.
2. Make sure that the outlet from the bin is large enough to prevent arching.

## **REFERENCES**

- (1) JENIKE, A. W. Storage and flow of solids. Univ. of Utah Eng'r. Exp. Station Bulletin 123, 1964

- (2) CARSON, J. W., T. A. ROYAL and D. J. GOODWILL Understanding and eliminating particle segregation problems. *Bulk Solids Handling*, 1986, 6, 139-144.
- (3) ANON. Testing series #4: Estimating flow rates of fine powders. *Flow of Solids® Newsletter*, 1989, IX, No. 2.
- (4) ANON. Testing series #3: Compressibility measurements serve many purposes. *Flow of Solids® Newsletter*, 1998, VIII, No. 2.
- (5) JOHANSON, J. R. Two-phase flow effects in solids processing and handling. *Chem. Eng.*, January 1, 1979, 77-86.
- (6) CARSON, J. W. and D. S. DICK Seals improve coal flow into a pressurized environment. *Power Eng'r.*, March 1988, 24-27.
- (7) BRUFF, W. and A. W. JENIKE A silo for ground anthracite. *Powder Tech.*, 1967, 1, 252-256.
- (8) CICCARIELLO, A. and J. POWERS Pyramidal bins ease flow of Kaolin clay at Filtrol. *Chem. Processing*, 1986, 49, No. 6, 30-31.
- (9) JOHANSON, J. R. and A. W. JENIKE Settlement of powders in vertical channels caused by gas escape. *J. Applied Mech.*, 1972, 39, 863-868.